



USER INSTRUCTION MANUAL
DEAD WEIGHT ANCHOR

THESE INSTRUCTIONS APPLY TO THE FOLLOWING MODEL:

UFA30061

CE 0598

EN 795:2012 Type E

Please read and understand the manufacturer's instructions for each component or part of the complete system. Manufacturer's instructions must be followed for proper use, care, and maintenance of this product. These instructions must be retained and be kept available for the user's reference at all times. Alterations or misuse of this product, or failure to follow instructions, may result in serious injury or death.

Note: The user is advised to keep this user instructions document for the life of the product.

This Anchor is classed as a Personnel Protective Equipment (PPE) by the European PPE Regulation (EU) 2016/425 and has been shown to comply with this Regulation through the Harmonized European Standard EN 795:2012 Type E.

Quick and Easy to install. These post deploys in the event of fall to absorb the energy hence leaves the roof panel intact to maintain architectural integrity.

1. PERFORMANCE AND LIMITATIONS OF USE: This Anchor has been tested in accordance with EN 795:2012 Type E and have achieved the following performance levels-

EN 795:2012 Type E test	Result/Comment
General Requirements for Anchor devices (Clause 4.1)	(PASS) No sharp edges (PASS).
Static Strength (Clause 4.4.2.3)	Sustained a force of 12 kN for 3 minutes (PASS).
Dynamic Strength & Integrity Test (Clause 4.4.1.2)	When tested with rigid steel mass of 100 kg, the test mass held after test with the device remaining stable throughout. (PASS). Anchor Holds an increased load of 300kg for 3 min following dynamic test.
Corrosion Resistance (Clause 4.2.2.1)	No corrosion evident after 48 hours of salt spray testing. (PASS)

2. DESCRIPTION:

- Dead Weight anchor post designed to be used as an anchorage point where structural anchors are not available for the users working near a potential fall hazard.
- Comes with polymer coated base plate to provide better grip and Stability with the mating surface.
- Compatible with different roof surfaces as Bitumin, asphalt and concrete, PVC, TPO.
- Comes with a central shock absorbing post with deploys in event of a fall.
- Anchor post can be used in different configurations to perform various activities such as-

S No.	Application	Counter Weight	No. of user
1	Anchor post for fall arrest	400 kg.	1
2	Suspension	400 kg.	1
3	Lifeline (Extremity Corner)	400 kg.	1
4	Lifeline Intermediate	300 kg.	1

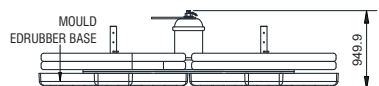
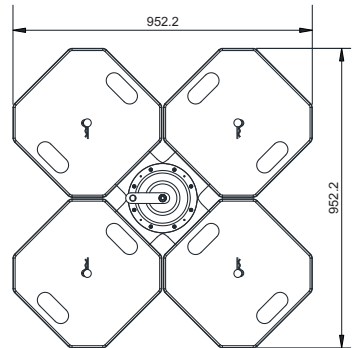

3. ADVICE & INFORMATION:

- It should be the personnel property of its user.
- It should not be used in highly acid or basic environments.
- The anchor has been tested to EN 795:2012 Type E and is appropriate only for single person use with an energy absorber as per EN 355:2002 that is rated to user mass up to 100kg.
- Ensure that the structure on to which the anchor is fitted is strong enough to withstand a load of 20 kN.
- Ensure that the equipment is compatible with other items when assembled into a system.
- It is essential to verify the free space required beneath the user at work place before each occasion of use so that in case of a fall there will be no collision with ground or other obstacle in the fall path.
- It is essential for the safety of user that if the product is resold outside the original country of destination, the reseller shall provide instruction for use, maintenance, for periodic examination and for repair in the language of the country in which product is to be used.
- Anchor device should be marked with the date of the next or last inspection done.
- Dead weight Bottom plate is made up of TPV material which is metallic reinforced.
- Anchor device should be positioned and the work carried out in such a way as to minimize both the potential for falls and potential fall distance.
- A full-body harness is the only acceptable body holding device that can be used in a fall arrest system.
- When the equipment becomes wet, either from being in use or when due to cleaning, it should be allowed to dry by itself and be kept away from open fire or any other source of heat.
- Standard packaging supplied from the manufacturer should be used during transportation to protect the equipment against damage.
- It is necessary for the user to carry out a pre-use check of equipment, to ensure that it is in a serviceable condition and operates correctly before it is used.
- It is important to conduct a regular periodic examination of the product because the safety of the user depends upon the continued efficiency and durability of the product.
- Periodic examination frequency shall be at least every 12 months.
- Periodic examinations are only to be conducted by a competent person strictly in accordance with the manufacturer's periodic examination procedure.
- Ensure that all markings on the product are legible and can be clearly read.

4. WARNING:

- Ensure the Medical condition of the user does not affect his safety in normal and emergency use.
- The equipment shall only be used by a person trained and competent in its safe use.
- A rescue plan shall be in place to deal with any emergencies that could arise during the work.
- Do not make any alteration or additions to the equipment without the manufacturer's prior written consent and repair shall only be carried out by personnel trained by the manufacture & duly authorized by him.
- The equipment shall not be used outside its limitation, or for any purpose other than that for which it is intended.
- The Anchor device should not be positioned in areas where water could accumulate and create a hazard.
- The Anchor device should not be used when there is a risk of frost, or in freezing conditions where frost or freezing conditions create a hazard.
- The Maximum angle from the horizontal surface permitted for the anchor device is 5 degrees.
- The device should not be used where there is Oil, grease or algae on the surface.
- The Anchor device should not be used in combination with retractable type fall arresters unless they have been tested together.
- When anchor devices are combined with energy-absorbing lanyards(EN 355) that have not been tested together may cause Major injury or even death.
- Where the users intend to combine any personal fall protection equipment for fall arrester with an anchor device, they should seek guidance on its suitability from the manufacturer before doing so.
- It is advised that where the device is to be used on a surface, that is covered with stone chippings, all loose stones should

be removed (e.g. by sweeping with a hard brush) before the assembly of the anchor device.

- Please check for any permanent deformation, cracks and cut marks on dead weight plates, if any defects are found it is not recommended to use without the advice of an authorized person.
- It is essential for safety that equipment is withdrawn from use immediately if any doubt arises about its condition for safe use or it has been used to arrest a fall and not used again until confirmed in writing by a competent person that it is acceptable to do so.
- Be aware of any dangers that may arise by the use of combinations of items of equipment in which the safe function of any one item is affected by or interferes with the safe function of another.
- Following conditions may be hazardous & may affect the performance of Anchor:-
 - Extreme temperature.
 - Trailing or looping of Lanyards over sharp edges.
 - Extreme acidic or basic environments.
 - Abrasive or sharp edge structures which can damage the equipment.
 - Chemical Reagents.
 - Climatic exposure.
- The maximum distance between intermediates and extremity will be 15 meters.
- The number of corners in the system depends on the site.
- The number of spans per system depends on the site requirements.

5. ENVIRONMENTAL HAZARDS:

Use of this equipment in areas with environmental hazards may require additional precautions to prevent injury to the user or damage to the equipment. Hazards may include, but are not limited to; heat, chemicals, corrosive environments, high voltage power lines, gases, moving machinery and sharp edges.

6. RESTRICTIONS REGARDING MAKING CONNECTIONS:

- Do not make connections where the hook locking mechanism can come into contact with a structural member or other equipment and potentially release the hook.
- Do not connect a snap hook into a loop or thimble of a wire rope or attach in any way to a slack wire rope.
- The snap hook must be free to align with the applied load as intended (regardless of the size or shape of the mating connector)
- A Karabiner may be used to connect to a single or pair of soft loops on a body support such as a body belt or full body harness, provided the karabiner can fully close and lock. This type of connection is not allowed for snap hooks.
- A karabiner may be connected to a loop or ring connector that is already occupied by an automatic closing connector.

If the connecting element that a snap hook (shown) or Karabiner attaches to is undersized or irregular in shape, a situation could occur where the connecting element applies a force to the gate of the snap hook or Karabiner. This force may cause the gate (of either a self-locking or a non-locking snap hook) to open, allowing the snap hook or Karabiner to disengage from the connecting point.

Unintentional Disengagement (Roll-Out)

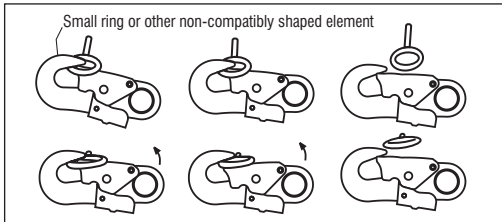

1. Force is applied to the snap hook.
2. The gate presses against the connecting Ring.
3. The gate opens allowing the snap hook to slip off.

Inappropriate Connections

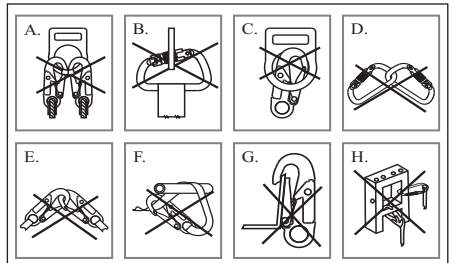

7. RESCUE PLAN:

Rescue operation must be performed by a trained and competent personnel. The rescue operation must be performed under the supervision of the rescue expert team or personal. It is advised that while working on site work in pairs. Before going for the work the user must have the rescue plan ready according to the work.

If Equipment Is Subjected To A Fall:

Remove the equipment from service immediately if it has been subjected to the forces of a fall arrest. Contact your distributor or KStrong about policies regarding replacement of KStrong components involved in a fall.

8. SPECIFIC INSTRUCTIONS:

KStrong Anchors are designed to provide complete attachment system to the user in the event of a fall. These attachment systems must be connected to the proper body support and connecting facility. These Anchors are meant to hold the victim of fall till the rescue operation is performed, so this is important that the whole system must have all the essential components before going for use. The whole fall arrest system must be used by a trained/competent person. It is advisable to make a checklist of the essential components according to one's use before going for work.

9. USE OF FALL ARREST SYSTEM:

The fall arrest system **MUST ONLY** be connected to the back attaching element on the harness provided for the purpose ("D" ring or webbing attachment extension) or to the chest anchorage points ("webbing link" or "D" link). The chest anchorage points must imperatively be used together. The D-rings on the belt and the ventral anchorage point must only be used for the attachment of a work positioning or retaining system and never with a fall arrest system.

During use, check regularly the adjustment and/or attachment points.

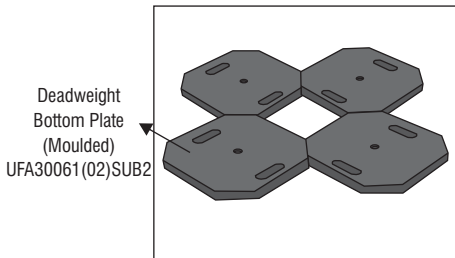
10. INSTALLATION OF SA 33: Identify the suitable placement for the Dead weight Anchor, ensuring it is both level and positioned a minimum of 13 feet (4 meters) from the structure's edge while maximizing proximity to the work zone.

First, place the anchor Bottom plate on the ground.

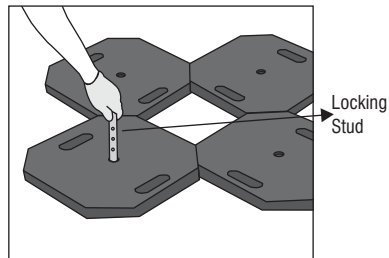

Screw the Locking stud to the anchor base plate.

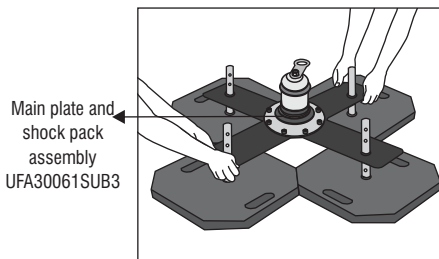

Place the dead weight main arm on the Locking stud.

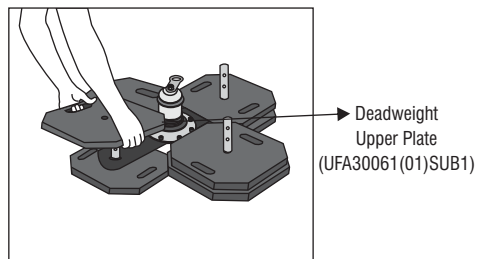

Now insert Dead weight on the locking stud.

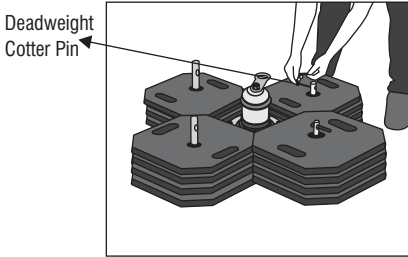

Once inserted, lock the weight by help of cotter pin.

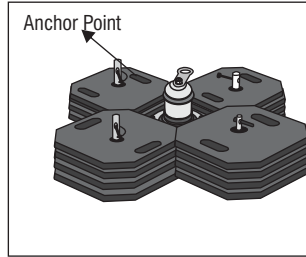

Now the anchor is ready to be used.

Note- Dead weight Anchor should be installed at minimum 4 meter of distance from the edge of roof.

11. **INSPECTION** : Visually inspect the system before each use to ensure that it is in a serviceable condition and is operating correctly. If during inspection, doubts are raised about the safety of the system or a component, these should be replaced either by the manufacturer or a competent person.
12. **COMPATIBILITY** : To optimize protection, in some instance it may be necessary to use the anchor with suitable boots/gloves/helmet/ear defenders. In this case, before carrying out the risk-related activity, consult your supplier to ensure that all your protective products are compatible and suitable for your application.
13. **STORAGE AND TRANSPORT** : When not in use, store the anchor in a well-ventilated area away from heavily acidic or basic environment. Never place heavy items on top of it. Also ensure that it is stored away from chemically hazardous environment preferably storage should be in dry environment.
14. **REPAIR** : If the product becomes damaged, it will NOT provide the optimum level of protection, and therefore should be immediately either replaced or repaired. Never use the damaged product. Repair is permitted, provided that it is either done by the manufacturer or a competent repair centre or individual approved by the manufacturer.
15. **CLEANING** : In case of minor soiling, wipe the anchor with cotton cloth or a soft brush. Do not use any abrasive material. For intensive cleaning wash the anchor in water at a temperature between 30°C to 60°C by using a neutral detergent (pH 7). The washing temperature should not exceed 60°C. Do not use acid or basic detergents.
16. **WITHDRAWAL FROM USE** : If the system has been used to arrest a fall, it should be removed from service and returned to the manufacturer or a competent repair centre for servicing and re test.

MARKING

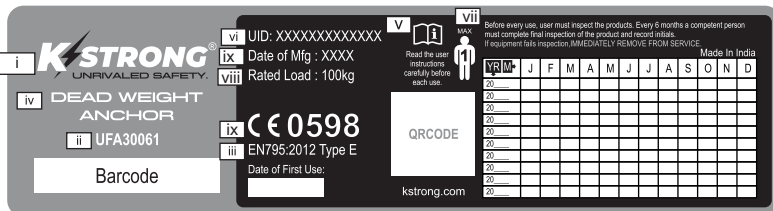

The Anchor Post is marked with:-

- | | |
|-------------------------------------|--|
| i) Identification of manufacturer. | v) UID for traceability |
| ii) Type of product code. | vii) For Single User Only |
| iii) Norm Reference. | viii) Rated Load |
| iv) Product description | ix) The 'CE' mark showing that the product meets the requirements of the PPE Regulation (EU)2016/425 |
| v) Read the instruction before use. | x) Date of Manufacturing. |

LIFESPAN: The estimated product Lifespan is 10 years from the date of first use. The following factors can reduce the Lifespan of the product: intense use, contact with chemical substances, especially aggressive environments, extreme temperature exposure, UV exposure, abrasions, cuts, violent impacts, bad use or maintenance.

DISCLAIMER: Prior to use, the end user, must read and understand the manufacturer's instructions supplied with this product at the time of shipment and seek training from their employer's trained personnel on the proper usage of the product. Manufacturer is not liable or responsible for any loss, damage or injury caused or incurred by any person on grounds of improper usage or installation of this product.

EQUIPMENT RECORD				
Product				
Model & type/Identification		Trade Name	Identification number	
Manufacturer		Address	Tel, email into use	
Year of manufacture		Purchase Date	Date first put into use	
Other relevant information (eg. document number)				
PERIODIC EXAMINATION AND REPAIR HISTORY				
Date	Reason for entry (periodic examination or repair)	Defects noted, repairs carried out and other relevant information	Name and signature of competent person	Periodic examination next due date

Certification Body:

SATRA Technology Europe Ltd, Bracetown Business Park, Clonee, Dublin D15 YN2P Ireland (Notified Body 2777)

Ongoing Assessment Body:

SGS Fimko Oy, Takomotie 8, FI-00380 Helsinki, Finland (Notified Body 0598)



KStrong Inc.
150 N. Radnor Chester Road Suite F200
Radnor, Pennsylvania 19087 United States
Contact number: 1-833-KSTRONG

www.kstrong.com

USA

South America

Asia

UKS/UFA30061/010224/V3