

## KStrong® BRUTE™ Sealed 50 ft. SRL with stainless steel cable and stainless steel swivel snap hook. Includes stainless steel installation carabiner and tagline (ANSI).

Model: UFS570050



50' Sealed Housing SRL with stainless steel cable and stainless steel load indicator swivel snap hook. Includes stainless steel installation carabiner and tagline.

### DESIGN

- Sealed design to restrict entry of dust, chemicals, fumes or any liquids inside to protect critical internal parts from contamination in off shore and areas where chemical hazard is evident
- Robust & durable polymer casing around metal chassis
- D-shackle at anchorage point for making connections
- Swivel stainless steel snap hook with load indicator at attachment end
- Stainless steel wire rope

### CABLE

Material: Stainless steel wire rope Ø3/16"  
Minimum Breaking Strength: 3800 lbs.

### LENGTH

50 Feet

### WEIGHT

32.19 lbs. ± 0.22 lbs. (14601 gm ±100 gm)

### RELEVANT STANDARDS

Meets or Exceeds ANSI Z359.14-2021 Class 1 & IP 68 Level of IEC 60539



FRONT VIEW

SIDE VIEW

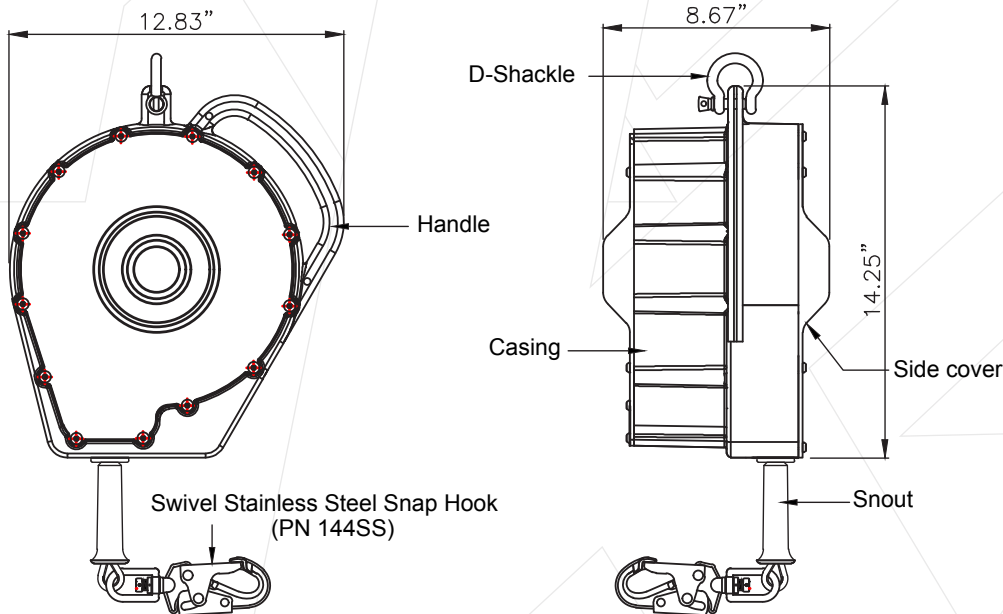

**Class 1**  
Anchor at or above dorsal D-ring

Batch #: \_\_\_\_\_ Serial #: \_\_\_\_\_  
Date of First Use: \_\_\_\_\_