

KStrong® Kapture™ Element Oil and Gas Derrick Deluxe Harness with 7 D-Rings and Removable Bosun Chair

Oil and Gas Derrick Deluxe Harness with 7 D-Rings and Removable Bosun Chair

MODEL	SIZE	WEIGHT
UFH90471G(S-M)	Small to Medium	10.67 lbs. ± 0.02 lbs. (4840gm ± 10gm)
UFH90471G(M-L)	Medium to Large	10.78 lbs. ± 0.02 lbs. (4890gm ± 10gm)
UFH90471G(L-XL)	Large to X-Large	10.89 lbs. ± 0.02 lbs. (4940gm ± 10gm)
UFH90471G(XL-2XL)	X-Large to 2XL	11 lbs. ± 0.02 lbs. (4990gm ± 10gm)

DESIGN

- Equipped with multiple D-rings to provide user application with derrick work including climbing and suspension
- Features 2.75" (70mm) wide integrated sling seat with Bosun seat attached to it
- Sling seat equipped with suspension D-rings
- Equipped with work positioning belt with padding for user comfort
- Equipped with Dorsal D-ring Extension
- Grommeted leg straps provides 9 positions of adjustment

WEBBING

Material: Polyester
Width: 1.73 in. ± 0.04 in. (44mm ± 1mm)
Breaking Strength: 5000 lbs.

STITCHING THREAD

Material: High-tenacity polyester

METAL COMPONENT

Material: Alloy Steel;
Finish: Silver or Golden Yellow Galvanized

RELEVANT STANDARDS

Meets or Exceeds ANSI Z359.11-2021

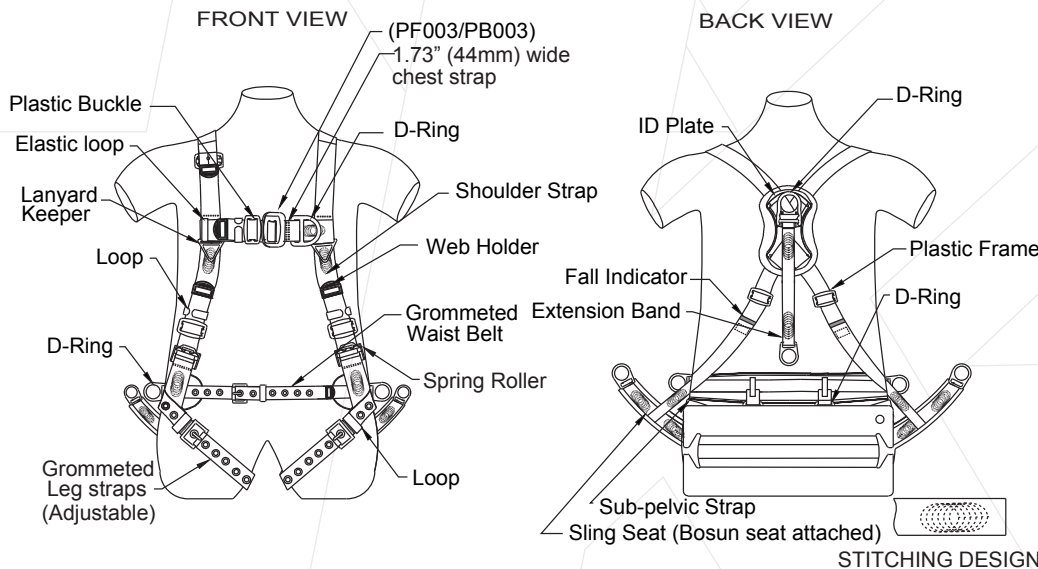

Batch #: _____ Serial #: _____
Date of First Use: _____