

DOUBLE TANDEM PULLEY SMALL WITH SS SHEAVES

AFX206004

Features

- Lightest, Fastest, Versatile double tandem pulley on ball bearing.
- Pulley is large enough to accommodate rope up to 16 mm diameter.
- Attachment Point can accommodate a connector up to 16 mm diameter.

How To Use

Refer to User Instruction Manual



Metal Components

Material	:	Aluminum Alloy (Side Cover) Stainless Steel (Sheaves)
Finish	:	Colored / Anodized (Side Cover) Polished (Sheaves)
Minimum Breaking Strength	:	45 kN



Weight

820 gm ± 25gm

Relevant Standards

EN 795:2012 TYPE B & EN 12278:2007

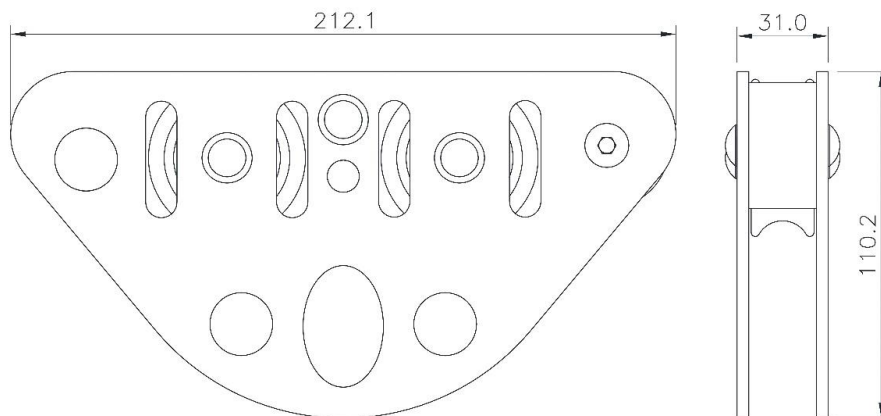

C € 0598