

EXTREME STAINLESS STEEL DAVIT

AFT7500

KStrong Extreme Stainless-Steel Davit has been designed to provide the user with a safe and secure system when working in Confined Spaces. Ideally suited for corrosive and wet environments such as Water treatment plants, Shipping and Food Processing plants.

Features

- Robust Stainless Steel for high corrosion resistance
- 360-degree swivel whilst on the mounting base or wall mount base
- The 15kn Cantilever arm has 3 defined adjustment points providing greater reach and access (refer image below)
- Twin anchorage points on cantilever arm rated at 15kN for fall arrest
- Single point Anchor point rated at 21kn at base of Mast allowing for two users to connect
- The davit is interchangeable between floor and wall mounts
- Compatible with the Brute Winch and the Brute Type 3 Rescue Retrieval winch
- Developed for use in safety and rescue as well as for lifting and lowering loads



How To Use

Refer to User Instruction Manual



Material

316 Stainless Steel

Polished

Weight

Cantilever Arm: 15.9kg

Boom Upright: 19.2kg

Rating

15kN

Maximum Load

300kg

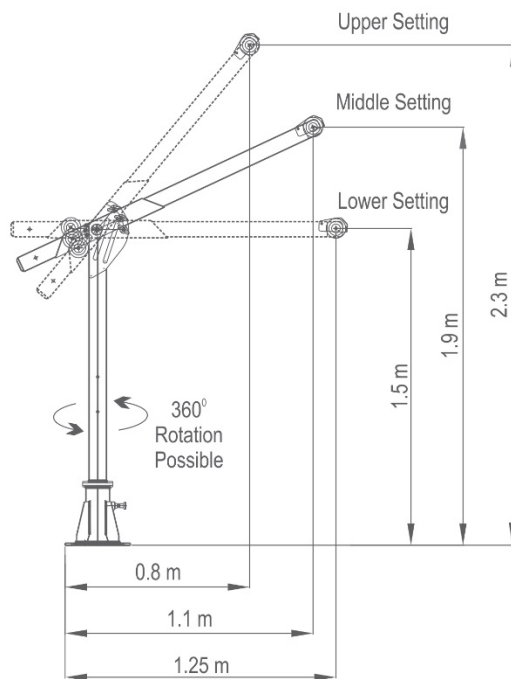

Relevant Standards

EN795:2012 Type A

Range of Accessories



Retrieval Retractable Blocks
(AFS510020R / AFS510030R)



Winch
(AFT730120 / AFT730140)



Davit Bracket (AFT7500B20) for
AFS510020R



Davit Bracket (AFT7500B30) for
AFS510030R



Floor mounting Bracket
(AFT7500BF)



WALL Mounting bracket
(AFT7500BW)