



AFF5000
HORIZONTAL
ALU-RAIL SYSTEM

USER INSTRUCTION MANUAL
&
TECHNICAL INFORMATION



MUST BE READ AND UNDERSTOOD PRIOR TO INSTALLATION



Disclaimer

The information provided in this User Instruction is based on the technical data that KStrong obtained under laboratory conditions and believes to be reliable. KStrong does not guarantee results and takes no liability or obligation in connection with this information. Since conditions of end-use are beyond our control, it is the user's responsibility to determine the hazard levels and the use of proper personal protective equipment. Persons having technical expertise should undertake evaluation under their specific end-use conditions, at their discretion and risk. Please ensure that this information is only to check that the product selected is suitable for the intended use. Any product that is damaged, torn, worn, or punctured should be discontinued from usage immediately.

CONTENTS

Know Your System	01
Standards	02
Instruction Guide	03
Job Safety Analysis	04
AFF5000 FALL ARREST SYSTEM COMPONENTS	06
Component Chart	07
Recommended PPE	07
AFF5000 Horizontal Anchorage Lifeline System on Rigid Aluminium Rail	08
Alu-Rail Extermity and Alu-Rail Intermediate	09
Mounting Nut and Wall Mounting Bracket Flush Type	10
Wall Mounting Bracket with Recess and Ceiling Mounting Bracket	11
Junction and Curved Alu. Rail (Outer Wall Mounted)	12
Curved Aluminium Rail (Inner Wall Mounted) and Curved Aluminium Rail (Outer Wall Mounted)	13
Trolley for Ceiling/Floor and Trolley For Wall	14
Inspection Plate: AFF115101H	15
INSTALLATION	16
General	16
Mounting Nut & Mounting Bracket (Ref.AFF5000)	16-18
Bend Ref. AFF5000	18-19
Trolley and Recommended PPE (Ref. AFF5000)	20
PRE- USE CHECKS & PRECAUTIONS	21
Post Installation Inspection	21
Precautions While Using the System	22
INSPECTION USE AND MAINTENANCE	23
PPE Inspection and Revalidation	23
Warranty	24
Tools Required	25-26
Proof Loading	27
Inspection Log	28



Know Your System

AFF5000 Horizontal Anchorage Lifeline System on Aluminium Line



The AFF5000 Anchorage Rail System is designed to provide safe anchorage for horizontal movement while working at height. The worker wears a full body harness and uses a lanyard (or other connector compliant with EN 354/EN 355) to connect to the eye of the trolley, which glides along the Aluminium Horizontal Rail. For overhead applications, a self retractable fall arrester can be used to provide the most effective means of fall protection.







The Aluminium Anchorage Rail can be fitted on to floors, walls and on ceilings using special mounting brackets. The wall mounting brackets can be flushed along the surface of the wall; alternately special mounting brackets which allow a recess between the rail and the wall may be used so as not to interrupt underlying structures like pipes and wires.

The rail is available in straight as well as curved forms (for corners and bends). The specially fixed junctions between different lengths of the rail allow an extremely smooth movement of the trolley.

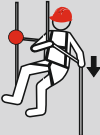
The AFF5000 Rail Fall Arrest System has been rigorously tested and manufactured in accordance with EN795:2012 Type D & TS 16415:2013 standards, ensuring you have quality and guarantee of any system installed onto your asset.

HORIZONTAL ANCHORAGE LINE SYSTEM

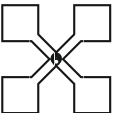
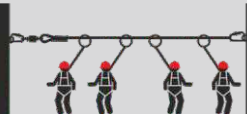
Standards

Standards		Description
EN 353-1		Guided type fall arresters including a rigid anchor line
EN 353-2		Guided type fall arresters including a flexible anchor line
EN 795 Type A		Anchor device requiring the fixing of one or more structural anchors
EN 795 Type B		Anchor device not requiring the fixing of one or more structural anchors
EN 795 Type C		Anchor devices using a horizontal flexible anchor line
EN 795 Type D		Anchor devices using a horizontal rigid anchor line
EN 795 Type E		Deadweight anchoring device
CEN/TS 16415:2013		Personal fall protection equipment - Anchor devices - recommendations for anchor devices for use by more than one person simultaneously
 II 2G Ex h IIc T6 Gb EN 80079-36:2016 EN 80079-37:2016		The ATEX directives are two EU directives describing the minimum safety requirements for workplaces and equipment used in explosive atmospheres

Must be Read Prior to Use

- Prior to use, ensure all operating procedures have been read and properly understood.
- This fall arrest system is only to be used by competent persons who have experience and training in the safe use of the system and associated equipment.
- Ensure all local workplace OH&S requirements are identified and understood.
- A risk assessment with a safe work method procedure must be completed and approved by management prior to work commencing.
- The system requires periodic inspection and maintenance by the manufacturer or their authorized representative as per EN365 of the PPE Regulation 2016.
- The system **MUST NOT** be used if the service date is overdue.
- A rescue plan must be formulated and ready for implementation prior to using any fall arrest system.
- Authorisation to access any risk area must be obtained from the person in control of the workplace.
- Only approved full body harness, lanyard and PPE certified either EN, ANSI or AS/NZS Standards is to be used with this system.
- Visually inspect the system for damage prior to use. The system must not be used if there is any deterioration or deformation of components or the structure to which the system is attached.
- If the safety system is damaged or has arrested a fall, discontinue use until it has been fully inspected and recertified by the manufacturer or their authorized representative.
- Ensure all fixings, fittings and components are securely attached. Any tightening, adjustment or replacement of components must be carried out by a competent person.
- Users must not be allowed to work alone in fall arrest situations in case emergency rescue assistance or first aid is required.
- All applicable EN Standards, Local OHS Acts & Regulations, and Codes of Practice & Guidelines must be read and obeyed when using this safety system.

Instructions for Periodic Examinations

- As per EN 365 of PPE Regulation 2016, it is necessary to carry out regular periodic examinations. The safety of the users depends upon the continued efficiency and durability of the equipment.
- The personal protective equipment shall be examined at least every 12 months.
- For corrosive/harsh environments, every 6 months (more frequent inspection may be required).
- The periodic examination can only be carried out by the manufacturer or their authorized representative.
- The comments should be included in the check card of the equipment. After the periodic examination, the next due date for periodic examination will be determined.
- During periodic inspection, it is necessary to check the legibility of the equipment marking.
- To check metals for sharp edge, burs, corrosion, bent profile distortion and opening & closing or such mechanisms for which that is intended for.

Remove from Service

- In case that it has been used to arrest a fall, the equipment must be withdrawn from use
- Labels have been removed, are missing or illegible
- Excessive abrasive wear has occurred
- Broken fibres, tears, cuts, snags and splinters are present
- Deterioration or stretching has occurred
- Parts and mechanisms are not moving freely or are corroded
- There is excessive contamination not removed by approved cleaning methods

HORIZONTAL ANCHORAGE LINE SYSTEM

Job Safety Analysis

Before commencing the job, it is recommended that the service technician / installer completes a JSA form, to identify hazards at site and to decide the correct PPE they need to mitigate the hazard. Refer to the example below.

Section 1 Job details					
JSA title	Project name		Work order or PID No.		
	Principal contractor				
Location / address				Date/s of activity	
Prepared by		Date prepared		Signature	

Permits required				Isolations required	
<input type="checkbox"/> Confined Space	<input type="checkbox"/> High risk work rescue plan	<input type="checkbox"/> High voltage access	<input type="checkbox"/> Roof Access	<input type="checkbox"/> Mechanical	<input type="checkbox"/> Hydraulic
<input type="checkbox"/> Work at height	<input type="checkbox"/> Excavation and trenching	<input type="checkbox"/> Energized work	<input type="checkbox"/> Other (please specify)	<input type="checkbox"/> Electrical	<input type="checkbox"/> Pneumatic
<input type="checkbox"/> Penetrating	<input type="checkbox"/> Grid mesh, flooring and guard rail removal	<input type="checkbox"/> Hot work		Site access required	<input type="checkbox"/> YES <input type="checkbox"/> NO

Section 2-Common hazards (Each Hazard identified below must be assessed)

Chemicals/hazardous substances		High-risk activities	
Name of chemicals or hazardous substance <input type="checkbox"/> SDS available		<input type="checkbox"/> Confined space	<input type="checkbox"/> Work at heights
		<input type="checkbox"/> Hot Work	<input type="checkbox"/> Excavation, trenching or penetrations
Energy sources		<input type="checkbox"/> Construction work	<input type="checkbox"/> Scaffolding
<input type="checkbox"/> Electricity	<input type="checkbox"/> Pressure	<input type="checkbox"/> Demolition	<input type="checkbox"/> Structural alterations
<input type="checkbox"/> Gas / Fuel	<input type="checkbox"/> Water	Work location	
Plant and equipment		<input type="checkbox"/> Sun	<input type="checkbox"/> Working over, in or near water
<input type="checkbox"/> Fixed Plant	<input type="checkbox"/> Mobile Plant	<input type="checkbox"/> Plants, Animals or Insects	<input type="checkbox"/> Contaminated / Flammable atmosphere
<input type="checkbox"/> Vehicles / boats	<input type="checkbox"/> Hand Tools	<input type="checkbox"/> Slips, trips and falls	<input type="checkbox"/> Work occurring in other areas
Manual tasks		<input type="checkbox"/> Biological hazards	<input type="checkbox"/> Fire
<input type="checkbox"/> Repetitive tasks	<input type="checkbox"/> Heavy Lifting	People	
<input type="checkbox"/> Awkward posture	<input type="checkbox"/> Sustained posture	<input type="checkbox"/> Remote or isolated work	<input type="checkbox"/> Contractors
Facilities / built environment		<input type="checkbox"/> Fatigue	<input type="checkbox"/> Visitors / land owners / public
<input type="checkbox"/> Buildings and fixtures	<input type="checkbox"/> On/in or adjacent to roadways	<input type="checkbox"/> Competency or training required	<input type="checkbox"/> License required
<input type="checkbox"/> Open pits, trenches or tunnels	<input type="checkbox"/> Asbestos/ lead	Environment and water quality	
<input type="checkbox"/> Overhead objects or services	<input type="checkbox"/> Underground objects or services	<input type="checkbox"/> Erosion & sediment control	<input type="checkbox"/> Waste/ discharge
<input type="checkbox"/> Lighting	<input type="checkbox"/> Noise	<input type="checkbox"/> Emissions (or air pollution)	<input type="checkbox"/> Flora/ fauna/ weed management
<input type="checkbox"/> On or near pressurized gas distribution mains or piping	<input type="checkbox"/> On or near chemical, fuel or refrigerant lines	<input type="checkbox"/> Release to drains/waterways	<input type="checkbox"/> Water quality

HORIZONTAL ANCHORAGE LINE SYSTEM

Activity List the task required to perform the activity in the sequence they are carried out.	Hazards Against each task, list the hazards that could cause injury when the task is performed.	Risk Control Measures List the control measures required to eliminate or minimize the risk of injury arising from the identified hazard.	Who is responsible? Write the name of the person responsible (supervisor or above) to implement the control measures identified.
Workers Names	Workers Signatures	Date	We, the undersigned employees acknowledge that we have assisted in the development of this JSA and have read and understood its contents. We agree to perform the work required in accordance with the instructions provided, including but not limited to the use of all listed PPE

Remember: • Each JSA must be site specific. • Include all workers in the development of this JSA.

Customercare@kstrong.com



HORIZONTAL ANCHORAGE LINE SYSTEM

AFF5000 Fall Arrest System Components

The rail system complies with EN 795:2012 Type D and TS 16415:2013 designed to provide safe anchorage for horizontal movement while working at height. Suitable for 4 users.

The rail system can be fitted on to floors, wall and on ceilings using special mounting brackets. The wall-mounting brackets can be flushed along the surface of the wall. Alternately, special mounting brackets which allow a recess between the rail and the wall may be used so as not to interrupt underlying structures like pipes and wires.

The rail is available in straight as well as curved forms (for corners and bends). The specially fixed junctions between different lengths of the rail allow an extremely smooth movement of the trolley.



Aluminium Rail Extremity
AFF531101

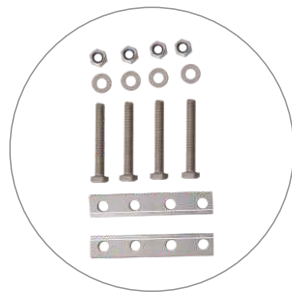

Junction
AFF533500



Trolley For Wall
AFF139010



Ceiling Mounting Bracket
AFF533700



Aluminium Rail Intermediate
AFF531100

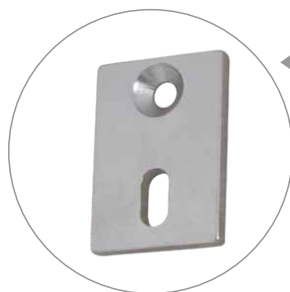

Wall Mounting Bracket
Flush Type
AFF533710



Wall Mounting Bracket
with Recess
AFF533720

HORIZONTAL ANCHORAGE LINE SYSTEM

Component Chart

The chart below shows all the components of the AFF5000 Horizontal Lifeline Systems with their appropriate reference numbers and quantity required in a system.

The trolley, mounting brackets and curved aluminium rail may be selected depending on the type of installation (wall, ceiling or floor).

TECHNICAL SNAPSHOT

Sr. No.	Component	Code	Qty. Required
1	Aluminium Rail Intermediate	AFF531100	Length of system
2	Aluminium Rail Extremity	AFF531101	2 no.
3	Mounting Nut	AFF533790	As per the number of mounting brackets
4	Wall Mounting Bracket Flush Type	AFF533710	At every 1 meter
5	Wall Mounting Bracket with Recess	AFF533720	At every 1 meter
6	Ceiling Mounting Bracket	AFF533700	At every 1 meter
7	Junction	AFF533000	1 no. for each Aluminium Rail Intermediate and Curved Alu. Rail
8	Curved AluRail (outer Wall Mounted)	AFF531010	As per number of bends
9	Curved Alu. Rail (Inner Wall Mounted)	AFF531020	As per number of bends
10	Curved Alu. Rail (Ceiling / Floor)	AFF531030	As per number of bends
11	Trolley For Ceiling / Floor	AFF139020	As per number of users
12	Trolley For Wall	AFF139010	As per number of users

Recommended PPE

While working on a roof, the user can select from a range of PPE to work safely with either lanyards, rope lines or SRL's in conjunction with a full body harness.



Energy Absorbing Webbing Lanyard
AFL408131



Work Positioning Lanyard with Grip Adjuster
AFL405111



Rope Line with Shock Absorber
AFA951201



2m Micron SRL
AFS550002



Full Body Roofers Harness
AFH300203

HORIZONTAL ANCHORAGE LINE SYSTEM

AFF5000 Horizontal Anchorage Lifeline System on Rigid Aluminium Rail



Aluminium Rail Extremity
AFF531101

- Material : Extruded Aluminium Alloy
- Length : 3 meter



Junction
AFF533500

- Material: Stainless Steel Grade 316



Trolley for Wall
AFF139010

- Material: Stainless Steel Grade 316 and Brass Wheels



Ceiling Mounting Bracket
AFF533700

- Material: Stainless Steel 316 (For Ceiling Mounting)

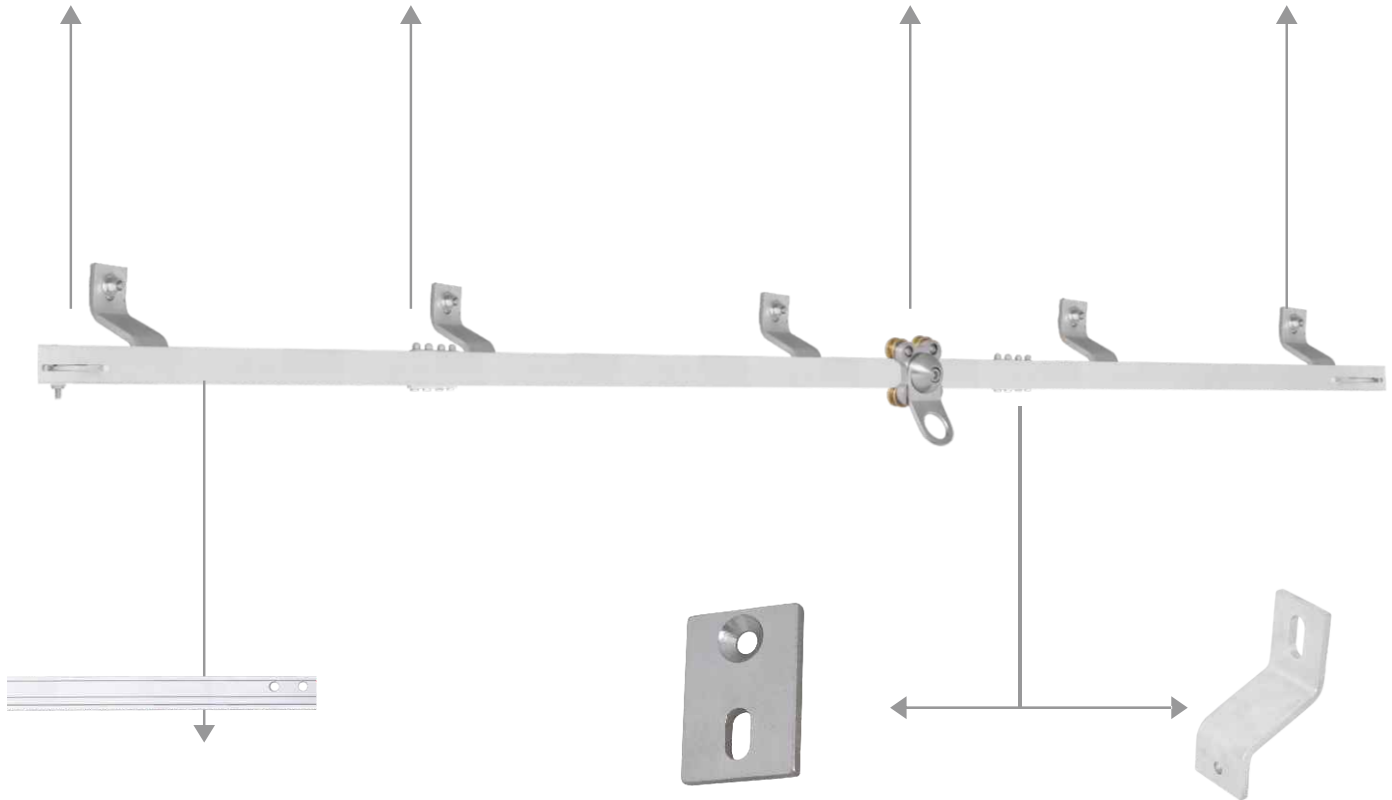

Aluminium Rail Intermediate
AFF531100

- Material : Extruded Aluminium Alloy
- Length : 3 meter



Wall Mounting Bracket
Flush Type AFF533710

- Material : Stainless Steel 316 (For FlushType Wall Mounting)



Wall Mounting Bracket
with Recess
AFF533720

- Material : Stainless Steel 316 (for Wall Mounting with Recess)

HORIZONTAL ANCHORAGE LINE SYSTEM

Alu-Rail Extermity

The Aluminium Rail extremity has a spring loaded termination which ensures that the trolley close not accidentally move off the rail.

TECHNICAL SNAPSHOT

Alu-Rail Extermity	AFF531101
Application	The aluminium rail extremity comes in a standard length of 3, 2.5, 2.0, 1.5,1 (meters) and can be connected to the aluminium rail intermediate by a junction . The aluminium rail extremity has a trolley halt jib at one end to prevent the trolley to move off the aluminium rail accidentally.
Material	Aluminium Alloy, T6
Weight	4.1 kgs



Alu-Rail Intermediate

The Aluminium Rail Intermediate is the aluminium rail on which the trolley slides smoothly without friction

TECHNICAL SNAPSHOT

Alu-Rail Intermediate	AFF531100
Application	The design of the aluminium section provides easy and friction free movement of the trolley. The aluminium sections comes in standard length of 3meters. The aluminium rails may be connected by a junction .
Material	Aluminium Alloy, T6
Weight	4.0 kgs for a length of 3 meters



Mounting Nut

The Mounting Nut slides smoothly in to the rear sections. The different kinds of wall mounting brackets may then be installed on the aluminium rail.

TECHNICAL SNAPSHOT

Mounting Nut	AFF533790
Application	To connect the aluminium rail intermediate to the mounting brackets
Material	Stainless Steel Grade 316
Weight	0.15 kg



Wall Mounting Bracket Flush Type

The aluminium rail system may be fixed close to the wall by the Flush Type Mounting Bracket.

TECHNICAL SNAPSHOT

Wall Mounting Bracket Flush	AFF533710
Application	Wall mounting bracket (flush type) are useful to mount the aluminium rail very close to the wall
Material	Stainless Steel Grade 316
Weight	0.15 kg



HORIZONTAL ANCHORAGE LINE SYSTEM

Wall Mounting Bracket with Recess

These Wall Mounting Brackets allow a recess between the aluminium rail system and the wall, so as not to interrupt underlying structures like pipes, wires etc.

TECHNICAL SNAPSHOT

Wall Mounting Bracket with Recess	AFF533720
Application	The special mounting bracket which allow a recess between the aluminium rail and the wall may be used so as not to interrupt underlying structures like pipes and wires
Material	Stainless Steel Grade 316
Weight	0.95 kg



Ceiling Mounting Bracket

This Bracket is best suited for mounting the aluminium rail system on the ceiling or on the floor .

TECHNICAL SNAPSHOT

Ceiling Mounting Bracket	AFF533700
Application	The aluminium rail system is fitted on the floor and ceiling with ceiling mounting brackets
Material	Stainless Steel Grade 316
Weight	1.16 kgs



HORIZONTAL ANCHORAGE LINE SYSTEM

Junction

The aluminium rail comes in standard lengths of 3 meters. When the span is more than 3 meters multiple lengths may be joined easily by the Junction Kit.

TECHNICAL SNAPSHOT

Junction	AFF533500
Application	Junction are provided to connect different sections of the aluminium rail system
Material	Stainless Steel Grade 316
Weight	1.16 kgs



Curved Alu. Rail (Outer Wall Mounted)

The aluminium rail is the best option for negotiating bends smoothly. AFF531010 is suitable for outer wall mounting application.

TECHNICAL SNAPSHOT

Curved Alu. Rail (Outer Wall Mounted)	AFF531010
Application	To negotiate curves when the aluminium rail system is installed on outer wall
Material	Aluminium Grade T6
Weight	3.0 kgs



HORIZONTAL ANCHORAGE LINE SYSTEM

Curved Aluminium Rail (Inner Wall Mounted)

The Aluminium Rail System is the best option for negotiating bends smoothly. AFF531020 is suitable for inner wall mounting application.

TECHNICAL SNAPSHOT

Curved Alu. Rail (Inner Wall Mounted)	AFF531020
Application	To negotiate curves when the aluminium rail system is installed on outer wall.
Material	Aluminium Grade T6
Weight	3.0 kgs



Curved Aluminium Rail (Outer Wall Mounted)

The Aluminium Rail System is the best option for negotiating bends smoothly. It is suitable for outer wall mounting application.

TECHNICAL SNAPSHOT

Curved Alu. Rail (Inner Wall Mounted)	AFF531030
Application	To negotiate curves when the aluminium rail system is installed on outer wall.
Material	Aluminium Grade T6
Weight	3.0 kgs



HORIZONTAL ANCHORAGE LINE SYSTEM

Trolley for Ceiling/Floor

The wheel type design of the Trolley ensures smooth friction less sliding over the aluminium rail system. The eye bolt on the top makes it suitable for ceiling or floor mounted installations.

TECHNICAL SNAPSHOT

Trolley For Ceiling/Floor	AFF139020
Application	The trolley guides along the aluminium horizontal rail mounted over the ceiling or floor
Material	Stainless Steel Grade 316 and Brass Wheels
Weight	1.0 kg
Conforms to	EN 353-1:2012



Trolley For Wall

The wheel type Trolley design ensures smooth friction less sliding over the aluminium rail system. This model is suitable for wall mounting installations.

TECHNICAL SNAPSHOT

Trolley For Wall	AFF139010
Application	The trolley guides along the aluminium horizontal rail mounted on the wall
Material	Stainless Steel Grade 316 and Brass Wheels
Weight	1.0 kg
Conforms to	EN 353-1:2012



HORIZONTAL ANCHORAGE LINE SYSTEM

Inspection Plate: AFF115101H

The Inspection Plate is installed on the tensioner side of the system for identification, traceability and maintenance of inspection records. At time of installation the relevant details are recorded on the ID tag. The next inspection dates are also recorded on the month and year on the back of the ID plate. The label is provided with a protective Aluminium frame with a poly carbonate sheet for UV protection. It is installed on the pin ring of the tensioner. The label is equipped with a dynamic QR code and an RFID tag that are linked to the Compass inspection software.

			
KStrong Horizontal Lifelines			
	AFF4000	Roof Mount - EN 795:2012 TYPE C and CEN/TS 16415:2013	
	AFF4000	Wall, Floor and Ceiling Mount - EN795:2012 TYPE D	
Date of Installation			
No. of users			
UID			
Line No.			
customercare@kstrong.com		www.kstrong.com/asia	

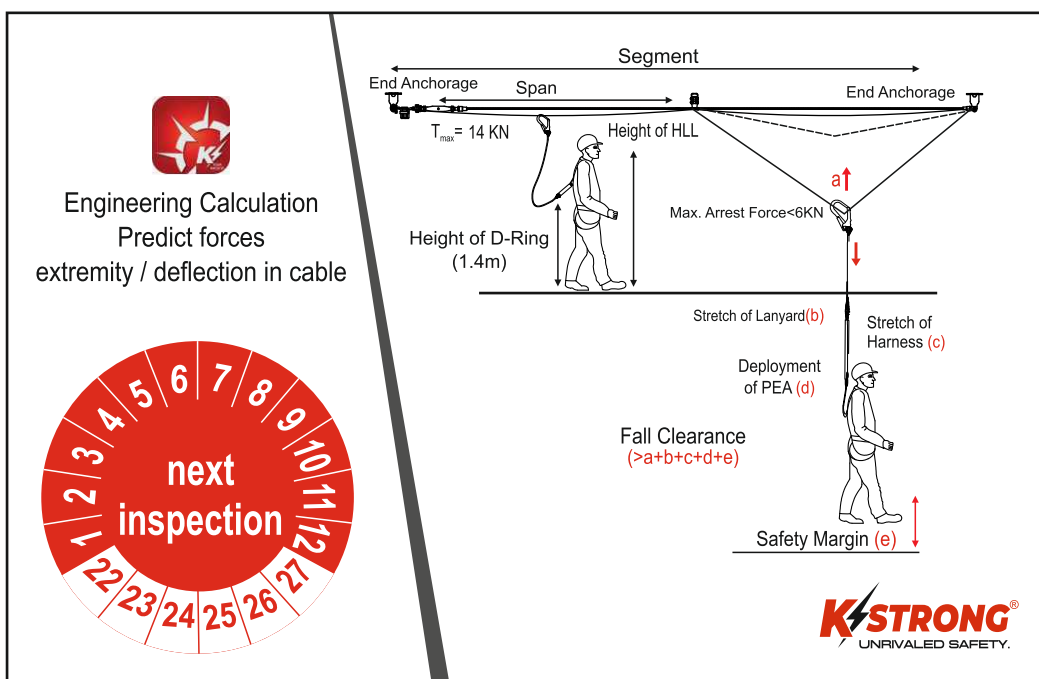

Installation

General

Installers Responsibilities

It is the installers responsibility to familiarise themselves with the European Standards and the local legislation prior to installing the safety systems. The end users must be trained in the use of KStrong safety systems and receive and understand the user instructions supplied.

The Safety System components manufactured and supplied by KStrong can only be used unless approval is given in writing prior to installation.

It is the installers responsibility to ensure that the "approved" fittings are fit for the purpose to ensure the system is fully warranted.

Under no circumstances can a KStrong component be modified or replaced by a component from another supplier.

⚠ The installation of the system shall be carried out only by trained authorized personnel of KStrong. The installation steps given below are a brief indication of the procedure, only for the purpose of information to the user. KStrong does not take any responsibility for consequences of installation of the system if it is carried out against an authorized written recommendation by KStrong. It is necessary to ensure the safety of the installer at all stages of installation through use of correct PPE. It is also important to use correct tools as recommended by KStrong for installation.

Ensure safety of the installer at all stages. Use correct PPE while installing.

Tools Required - Refer to Page Nos. 25 & 26

Mounting Nut & Mounting Bracket (AFF5000)

STEP 1: MOUNTING NUT Ref. AFF533790

- Insert the mounting nut in the channel as shown in the drawing. The mounting brackets may then be connected to the rail by a fastener.

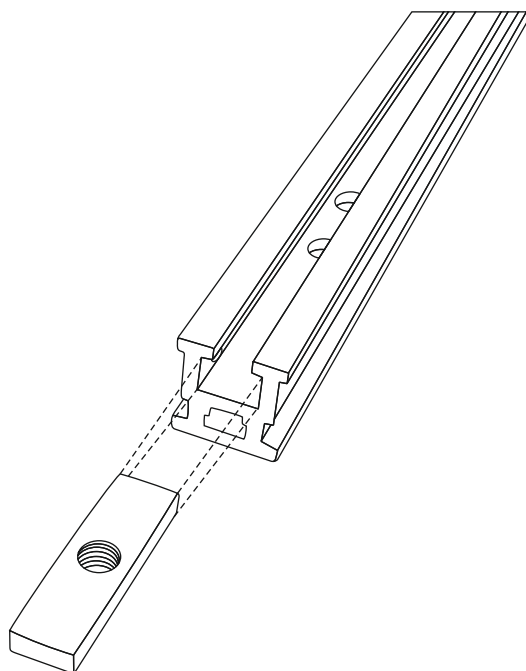

HORIZONTAL ANCHORAGE LINE SYSTEM

STEP 2A: WALL MOUNTING BRACKET FLUSH TYPE: AFF533710

- Connect the bracket to the mounting nut as shown in the drawing.
- To install the mounting bracket in concrete use 12 mm chemical fasteners.
- Optional Accessory: chemical fastener SA 12(04)
- Concrete: 25 MPa

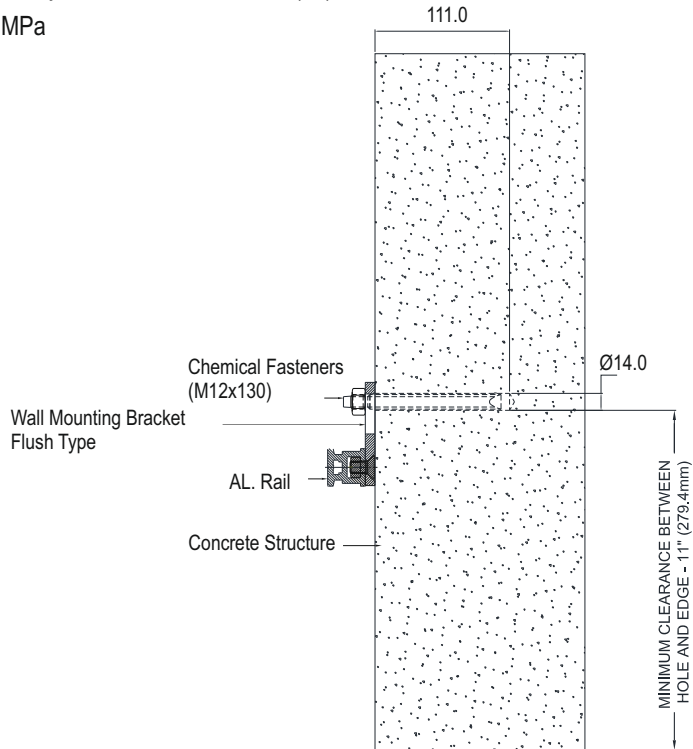

STEP 2B: WALL MOUNTING BRACKET WITH RECESS: AFF533720

- Connect the bracket to the mounting nut as shown in the drawing.
- To install the mounting bracket in concrete use 12 mm chemical fasteners.
- Optional Accessory: chemical fastener SA 12(04)
- Concrete: 25 MPa

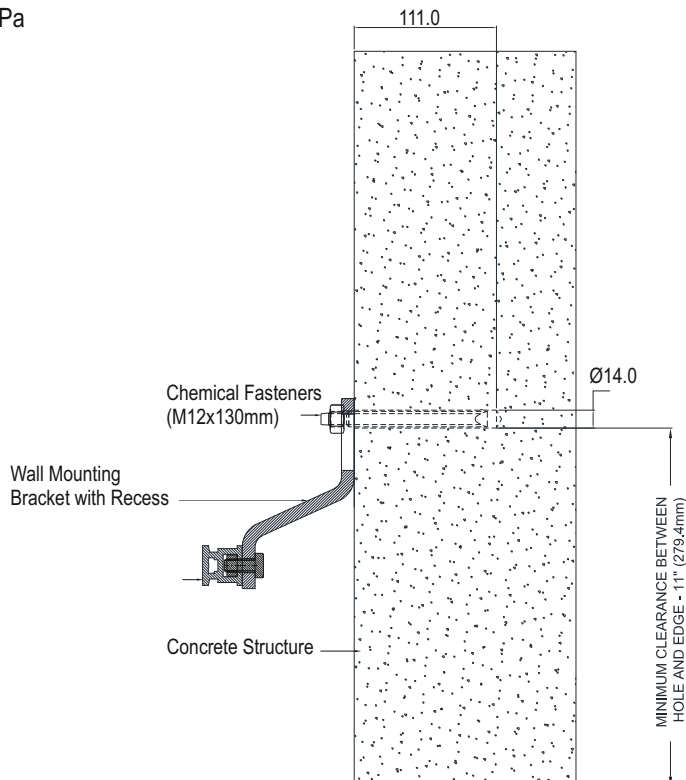

HORIZONTAL ANCHORAGE LINE SYSTEM

STEP 2C: CEILING MOUNTING BRACKET: AFF533700

- Connect the bracket to the mounting nut as shown in the drawing.
- To install the mounting bracket in concrete use 12 mm chemical fasteners.
- Optional Accessory: chemical fastener SA 12(04)
- Concrete: 25 MPa

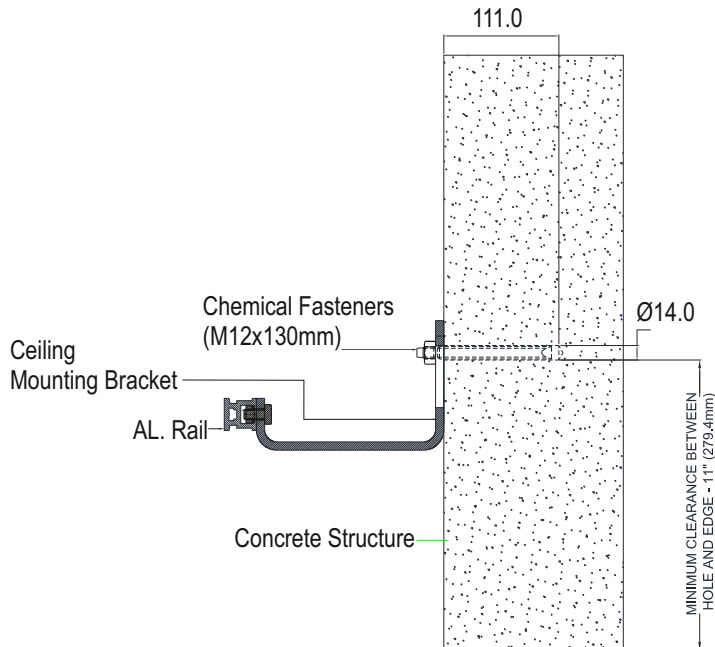

Bend (AFF5000)

STEP 3A: CURVED ALUMINIUM RAIL (OUTER WALL MOUNTED): AFF131010

- Join the curved rail with the intermediate. Match both sections of the rail.
- Place the junction plate on either side of the rail with the holes of junction plate matching with those of rail intermediate and curved rail.
- Fix both the plates by using 4 sets of fasteners.
- Ensure that the gap between the two rails is not greater than 1.5 mm.

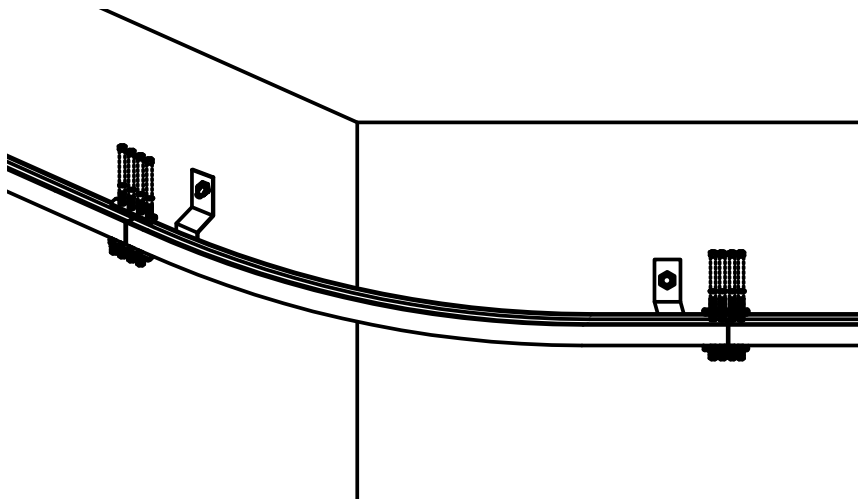

HORIZONTAL ANCHORAGE LINE SYSTEM

STEP 3B: CURVED ALUMINIUM RAIL (INNER WALL MOUNTED): AFF131020

- Join the curved rail with the rail intermediate. Match both sections of the rail.
- Place the junction plate on either side of the rail with the holes of junction plate matching with those of rail intermediate and curved rail.
- Fix both the plates by 4 sets of fasteners.
- Ensure that the gap between the two rails is not greater than 1.5 mm.

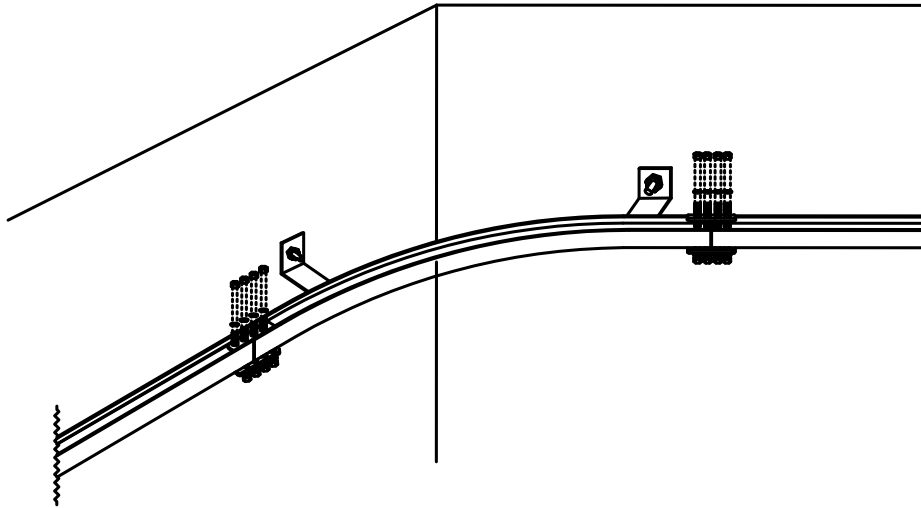

STEP 3C: CURVED ALUMINIUM RAIL (FLOOR/CEILING): AFF131030

- Join the curved rail with the rail intermediate. Match both sections of the rail.
- Place the junction plate on either side of the rail, with the holes of junction plate matching with those of rail intermediate and curved rail.
- Fix both the plates by 4 sets of fasteners.
- Ensure that the gap between the two rails is not greater than 1.5 mm.

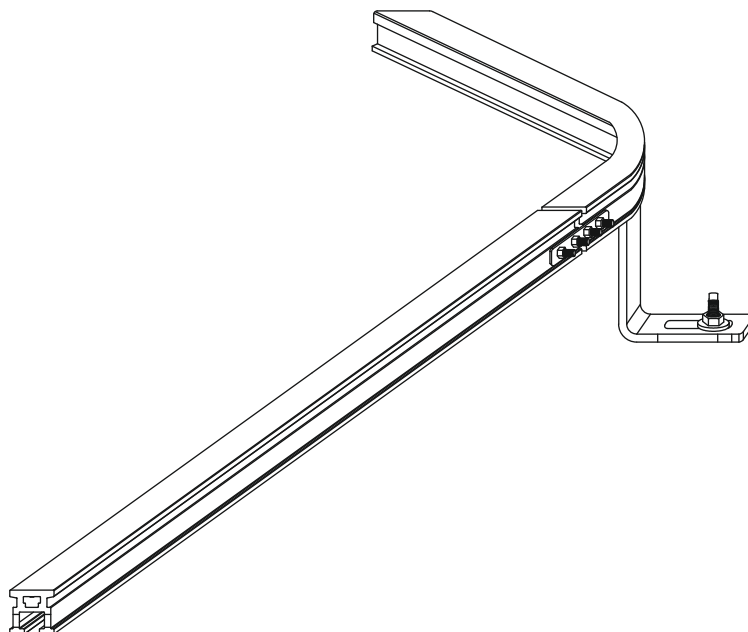

Trolley and Recommended PPE (AFF5000)

STEP 4A: TROLLEY FOR WALL AFF139010

- Insert the trolley in the aluminium rail extremity. Press the termination of the extremity and pass the trolley over the termination.
- After the trolley slides on the aluminium rail the termination comes back to its original position ensuring that the trolley does not slide off the aluminium rail.

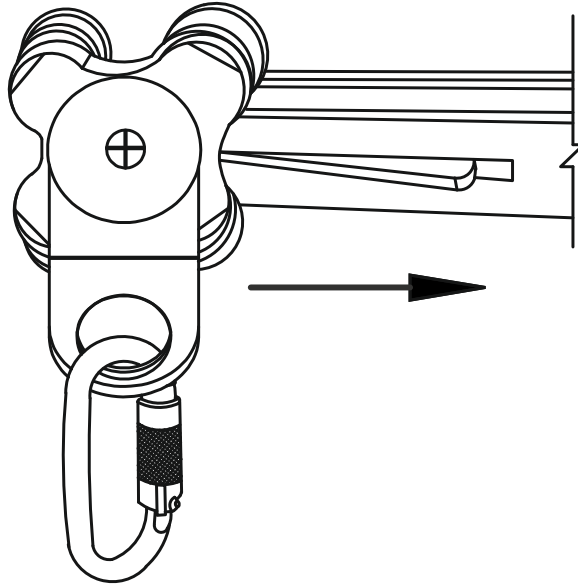

STEP 4B: TROLLEY FOR CEILING/FLOOR: AFF139020

- Insert the trolley in the aluminium rail extremity. Press the termination of the extremity and pass the trolley over the termination.
- After the trolley slides on the aluminium rail the termination comes back to its original position ensuring that the trolley does not slide off the aluminium rail.

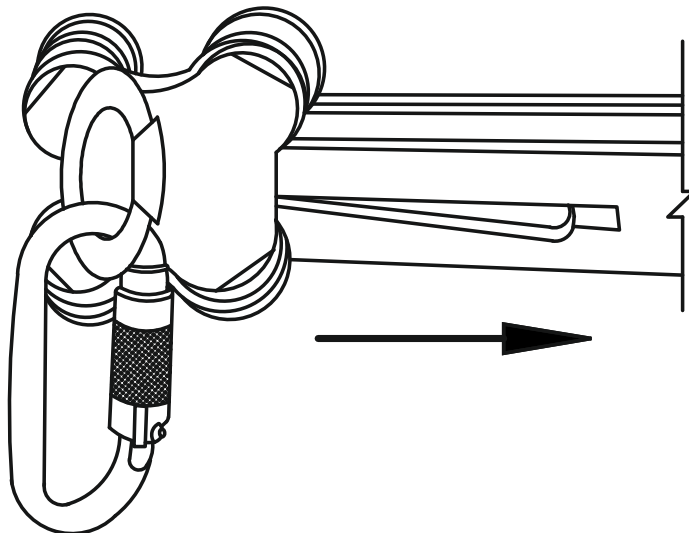

Pre-Use Checks and Precautions

Post Installation Inspection

- Once installed, it is important to inspect the complete line by moving the entire length of life line
- It is mandatory for the Site Inspector/ Supervisor and the actual users of the system to perform a thorough check before carrying out work. KStrong conducts a brief training of all concerned personnel on the subject of pre-use inspection of the system as per a defined guideline after the system has been installed by KStrong personnel.

Checking the receiving structure

Do not install the system if the receiving structure does not meet the minimum structural strength of 12kN. If in doubt, refer to an engineer.

Checking the System

- Clean the system from dust/dirt. Check for any mechanical defects.
- Check for wear and tear in all components or unusual bending or deformation.
- Check for any modifications done by the user.
- Check for any missing component.
- Check for any damages that may have been caused due to welding while maintenance of other equipment.
- Check the identification plate. The system needs to be put out of service if the label is not legible or missing.

Checking the Trolley

- Check the smooth movement of the Trolley before each usage. If friction is noticed, It can be due to dust accumulated due to continuous use. Clean the trolley with a soft cloth using silicon spray
- Only use a karabiner at the termination end of the lanyard to slide the trolley on the rail.

HORIZONTAL ANCHORAGE LINE SYSTEM

Precautions Need to be Considered for Safe Use of the System

The following points and precautions needs to be considered for safe use of the system

- The life line is for the purpose of fall protection while working on a horizontal plane at height. A back up fall arrest system is required when transitioning on and off the life line system while working at height.
- Never disengage the fall arresting lanyard and the carriage body from the life line while working at height.
- Avoid using grease to lubricate the system. If any fall is reported put the system out of use. Contact the manufacturer for repairs and re-validation.
- Only certified full body harness with proper attachment anchorage points should be worn while using the AFF5000 system.
- Do not alter or misuse this equipment. Always take the advice from KStrong personnel while using this equipment in combination with components or subsystems other than those described in this manual. Usage of certain component/sub system may interfere with the proper functioning of this equipment and the system may not deliver or work as per its intended use. In such case, KStrong may not be held responsible for any malfunction.
- The lifelines must be kept free from dust, grease, etc. by periodic cleaning. The system can be cleaned by a soft dry cloth.

Hazards

Hazards existing in immediate environment may require additional precautions to limit the possibility of injury to the user or damage to the equipment. Hazards may include but are not limited to, extreme temperatures, caustic chemicals, corrosive environments, high voltage power lines, explosive or toxic gases, moving machinery, sharp edges, high velocity winds, etc.

Do not expose the equipment to any hazard which it is not designed to withstand. Consult the manufacturer if in doubt.

Rescue Plan

It is recommended to ensure that the user shall have a rescue plan and means to execute it while using this equipment. The rescue plan needs to be project specific. The employees must be trained in self-rescue or alternative means shall be provided for prompt rescue in an event of a fall.

It is recommended to work in a pair to ensure that in an event of a fall your partner may help in rescue.

Annual Inspection & Revalidation

According to the requirement of EN365, every PPE needs to be inspected at least once in a year. The KStrong Compass software maintains the data of the system for at least 20 years and reminds the client whenever the inspection is due. The KStrong Inspection Team is trained to perform the inspection and provide a certificate each year at a nominal cost. The client may at any given moment of time extract the status of any of the lifeline installed anywhere in the world from the KStrong data base.

Environment

To protect the environment, KStrong follows a 100% paperless process. Unless specifically required, KStrong avoids printing its reports and make it available to the client digitally.

HORIZONTAL ANCHORAGE LINE SYSTEM

Inspection Use and Maintenance

PPE Inspection and Revalidation

Fall Protection Equipment is a life saving product. As per the EN 365 of PPE regulations 425/2016, it is mandatory to have a 'Competent Authority' to inspect the Fall Protection Equipment at least once annually.

KStrong Compass Inspection software helps taking care of the equipment.



- Cloud based online as well as off line software
- Captures geo coordinates where the system is installed
- RFID / Bar code compliant
- Generates report in real time
- Reminds user of items due for inspection
- Captures images of components
- User customizable
- Can be integrated to client software
- Reports can be shared with multiple recipients in real time

Infrastructure

- Good quality equipment complying with international standards
- 100% backward oriented manufacturing unit
- Qualified engineering team
- Sophisticated test equipment
- Precise engineering software to understand the client requirement to provide a safe & optimum solution
- Technical marketing team capable of understanding the client requirement & present the solution using engineering drawings (Auto CAD) & calculations
- Force predictions on the system in an event of a fall and a testing facility to validate the force calculations

HORIZONTAL ANCHORAGE LINE SYSTEM

Fixed Life Line System Projects can be Executed in 3 steps :

Site Visit

- Site engineer visits the client's site to check & understand the requirement.
- Site measurements using sophisticated equipments like digital distance meter & special imaging tools.
- Simulations of forces on the receiving structure using advanced engineering software like STADPRO.

Providing Good Quality Material

- MOC of KStrong fixed line components is Stainless Steel Grade 316 and Aluminium which are tested using a spectrophotometer to ensure the quality parameters.
- State of the art test lab using high precision dynamometers, oscilloscopes & slow motion cameras to validate predictions & simulations claimed.
- The only manufacturer having 100% backward oriented plant & undertaking to supply spares for a minimum period of 20 years.

Installation

- Proof loading of the system using Hydra Jaws (UK) equipment for onsite Horizontal Life Line testing: Post Execution Care
- Software based support for inspection of the system annually.

Warranty

The system is produced with extreme precision. Should there arise a manufacturing defect within a period of 1 year of supply, KStrong stands to repair the components or replace if necessary.

Warranty does not cover:

- Deficiency arising out of misuse of equipment
- Malfunction due to faulty installation/wrong usage of product
- This equipment is not user maintainable. The warranty stands void if an attempt is made to repair or open the equipment.

KStrong does not provide a product functioning warranty; the warranty stands for the workmanship of the products only.

- KStrong systems are made of stainless steel grade 316, ED Coated Steel or Aluminium and are highly resistant to corrosion.
- KStrong systems are thus further warrantied for 20 years (15 years for Marine Environment) provided they are inspected once annually according to the requirements of EN365.

HORIZONTAL ANCHORAGE LINE SYSTEM

Tools Required



RING SPANNER



DOUBLE END SPANNER



SOCKET SET



TENSIONER TIGHTENING TOOL



CRIMPING PLIER



BOLT CUTTER



ALLEN KEY

Machines



CORDLESS DRILL MACHINE



HAMMER DRILL MACHINE



CORDLESS IMPACT WRENCH



HYDRA JAWS
LIFELINE TESTING



SWAGING TOOL



HYDRAULIC CRIMPING HEAD







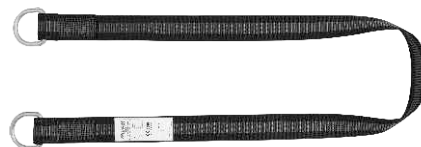
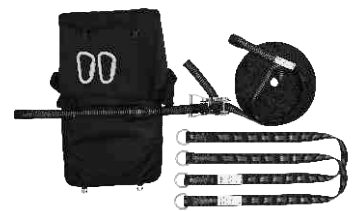
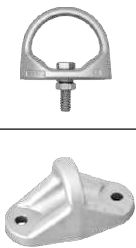

POWER BIRD RIVETING MACHINE

Anchors



HORIZONTAL ANCHORAGE LINE SYSTEM

Measuring Tools

					
TAPE	DETECTOR	DIGITAL TORQUE WRENCH	DISTANCE METER	LASER TOOL	VERNIER

Consumables, Miscellaneous Tools

						
DUST PUMP	HOLE SAW CUTTER	HOT AIR GUN	SETTING TOOL	PAINT BRUSH	DRILL BIT	IMPACT DRILL
						
BLOWER	CHEMICAL APPLICATOR					

WRENCH SIZE						
Hex Bolt	6	8	10	12	16	
Wrench Size	10	13	16	19	24	
Socket Size	10	13	16	19	24	

ALLEN KEY SIZE						
Allen Bolt Size	6	8	10	12		
Allen Key Size	4	6	8	10		
Allen Grub Screw Key Size	3	4	5	6		

Torque Chart (Maximum torque for standard bolts)

CHART						
Bolt size	6 mm	8 mm	10 mm	12 mm	14 mm	16 mm
Recommended Torque:	18 Nm	55 Nm	88 Nm	118 Nm	155 Nm	200 Nm

HORIZONTAL ANCHORAGE LINE SYSTEM

Proof Loading

Process of Proof Loading of Horizontal and Vertical Life Lines

Proof loading of roof post (Non Destructive)

- Post installation at least 10% of the posts should be proof loaded by a load testing device .The posts should be subjected to a static load of 1.0 kN for a period of 1 minute in accordance with EN 795 (4.4.1.1).The permanent deflection as a result of proof loading should not be greater than 10 mm after the load is released

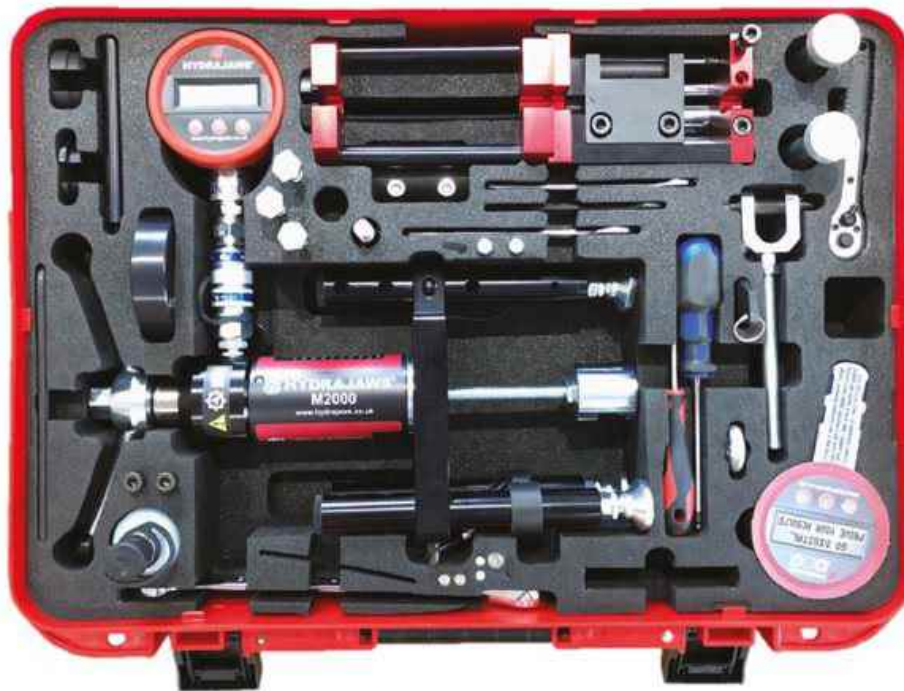

HYDRA JAWS LIFELINE TESTING

HORIZONTAL ANCHORAGE LINE SYSTEM

Inspection Log

EQUIPMENT RECORD				
Product				
Model & type/Identification		Trade Name		Identification number
Manufacturer		Address		Tel, Email
Year of manufacture		Purchase Date		Date first put into use
Other relevant information (eg. document number)				
PERIODIC EXAMINATION AND REPAIR HISTORY				
Date	Reason for entry (periodic examination or repair)	Defects noted, repairs carried out and other relevant information	Name and signature of competent person	Periodic examination next due date



KStrong Asia Pte Ltd
33A Chander Road,
Singapore 219539
Email: customercare@kstrong.com

www.kstrong.com

USA

South America

Asia
