

IMPACT CORNER POST FOR TRAPEZOIDAL ROOF SHEETS (AFF4000)

AFA935430

Features

- Corner post designed to be fixed on the trapezoidal roof with a minimum thickness of 0.40mm.
- Built in energy absorbing intermediate reducing the impact on users and roof profiles in the event of a fall.
- Available in following variants depending upon the angle:
 - AFA935430(60) 60 degrees
 - AFA935430(90) 90 degrees
 - AFA935430(120) 120 degrees.
- Simple and easy to install by using rivets and selected rivets to be fixed directly onto the Purlin for added strength.
- Compatible with pitch range from 195 mm to 305 mm on trapezoidal sheets.
- Provided with EPDM rubber for waterproofing.
- Rated for 4 users when used in a Lifeline System.

How To Use

Refer to User Instruction Manual



Metal Components

Base Plate	:	316 Stainless Steel : ED Coated Grey
Corner	:	316 Stainless Steel: Electro-Polished
Bolt	:	316 Stainless Steel
Minimum Breaking Strength	:	15 kN

Weight

2.18 kg ± 0.02 kg

Relevant Standards

Conforms to EN 795:2012 TYPE C & TS16415:2013

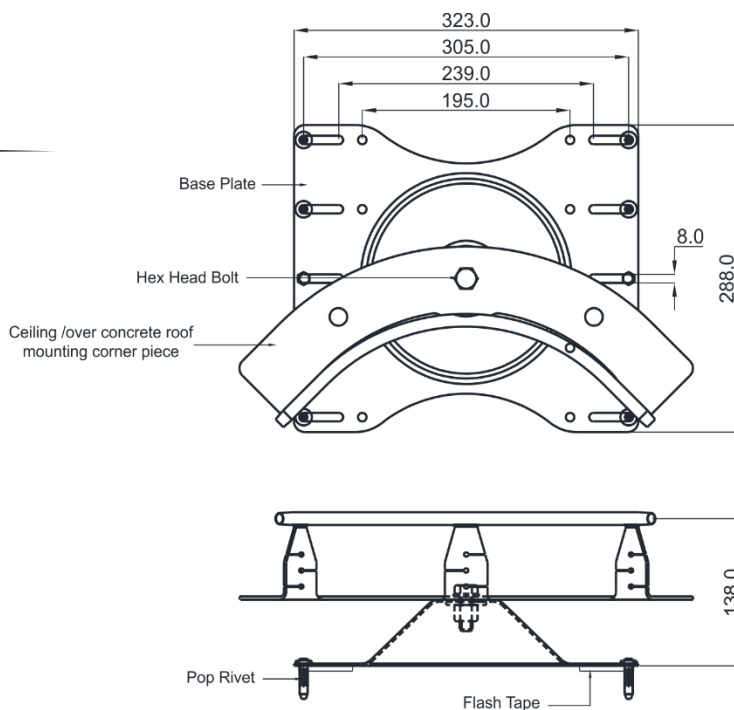

CE 0598