



USER INSTRUCTION MANUAL
SWIVEL CONNECTORS

CE 0598
VG11.135

THESE INSTRUCTIONS APPLY TO THE FOLLOWING MODELS:

AFX200630, AFX200631, AFX200632, AFX200633

Please read and understand the manufacturer's instructions for each component or part of the complete system. Manufacturer's instructions must be followed for proper use, care, and maintenance of this product. These instructions must be retained and be kept available for the user's reference at all times. Alterations or misuse of this product, or failure to follow instructions, may result in serious injury or death.

Note: The user is advised to keep this user instructions document for the life of the product.

- 1. INTRODUCTION** These Swivel Connector are classed as a Personal Protective Equipment (PPE) by the European PPE Regulation (EU) 2016/425 and has been shown to comply with this Regulation through the Harmonized European Standard VG11.135 .
These Swivel Connectors are designed to minimise the risk of/ provide protection against the danger of falling from heights. **However, always remember that no item of PPE can provide full protection and care must always be taken while carrying out the risk related activity.**
- 2. PERFORMANCE AND LIMITATIONS OF USE:** The Swivel Connector have been tested in accordance with VG11.135 and have achieved the following performance levels:

VG11.135 test	Result/Comment
Clause 4.1 Design and Ergonomics	Achieves required performance requirement
Clause 4.2 Material & Construction	Achieves required performance requirement
Clause 4.5 Static strength	Achieves required performance requirement

3. DESCRIPTION:

S.No.	Ref. No	PARTICULAR	MATERIAL	M.B.S.
1	AFX200630	OPENABLE SWIVEL ASSEMBLY	Aluminium Alloy	23kN
2	AFX200631	SWIVEL ASSEMBLY	Aluminium Alloy	23kN
3	AFX200632	ONE SIDE OPENABLE SWIVEL ASSEMBLY	Aluminium Alloy	23kN
4	AFX200633	SWIVEL RING ASSEMBLY SIDE OPENING	Aluminium Alloy	23kN

INSTALLATION AND USAGE STEPS FOR -

AFX200630-

1. Twist the Pin ring open from the threaded locking pin on either lower or upper side of the ring.
2. Now, unscrew the threaded locking pin and pull it open to open space for insertion of connector or lanyard thimble.
3. Insert a thimble/loop/connector in the open space, push the pin through it and twist the threaded locking pin to close it.
4. Lock the threaded locking pin using the Pin ring.
5. Repeat the same process for the other side of the swivel ring.
6. The Swivel Connector is connected and ready for use.

AFX200631-

1. Let the chosen end of the Swivel Assembly (upper or lower) be stitched through webbing lanyard loop or thimble. This enables a permanent connection OR
2. Connect the chosen end of the Swivel Assembly using any metal connector attached to a lanyard or rope.
3. Repeat the same process for the other end of the swivel assembly
4. The Swivel connection is ready for use.

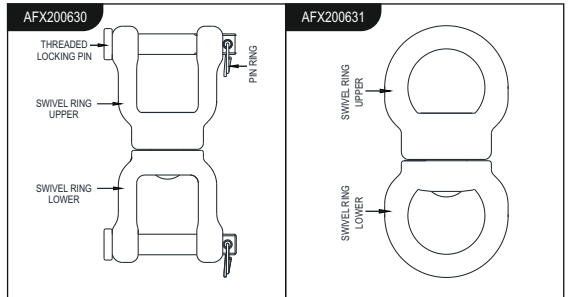

AFX200632-

1. Twist the Pin ring open from the threaded locking pin present on the upper side of the swivel assembly.
2. Now, unscrew the threaded locking pin and pull it open to open space for insertion of connector or lanyard thimble.
3. Insert a thimble/loop/connector in the open space, push the pin through it and twist the threaded locking pin to close it.
4. Lock the threaded locking pin using the Pin ring.
5. Now, use the other (Swivel Ring Lower) end for further connection using connectors as the One Side Openable Swivel Assembly is ready to use.

AFX200633-

1. First, unscrew the anchorage eye gate on either side of the Swivel Ring Assembly. This will open the lock for Anchorage eye gate.
2. After unscrewing, push the Anchorage Eye Gate open to enable insertion of webbing loop/thimble/connector through it.
3. Now, release the Anchorage Eye Gate through the space between the loop/thimble/connector, for it to close the gate/opening.
4. Twist the screw on the anchorage eye gate to close and lock its hold.
5. Repeat the same process for the other side of the Swivel ring assembly to ensure complete connection.
6. The Swivel Ring Assembly Side with Opening is now ready to use.

4. **INSPECTION:** Visually inspect the system before each use to ensure that it is in a serviceable condition and is operating correctly. If during inspection, doubts are raised about the safety of the system or a component, these should be replaced either by the manufacturer or a competent person.

5. PRECAUTIONS:

- Ensure the medical condition of the user does not affect his safety in normal and emergency use.
- The equipment shall only be used by a person trained and competent in its safe use.
- A rescue plan shall be in place to deal with any emergencies that could arise during the work.
- When intended to be used in a fall arrest system, it is essential for safety to verify the free space required beneath the user at workplace before each occasion of use, so that in case of a fall there will be no collision with the ground or other obstacle in the path.
- Avoid situations that may reduce the strength of connector eg. connecting to wide straps.
- Ensure that the equipment is compatible with other items when assembled into a system.

6. PRE-USE CHECK :

- It is important to check before use, any dangers that may arise by the use of combinations of items of the equipment in which the safe function of any one item is affected by or interferes with the safe function of another.
- Carry out a pre-use check of the equipment, to ensure that it is in a serviceable condition and operates correctly before it is used. Equipment should not have any cracks, deformation, damages or rusts on gate , lock should be move freely.
- Ensure the compatibility of items of equipment when assembled into a system.

8. **ANCHORAGE STRENGTH :** Equipment should be attached with Anchor / connection point having strength greater than 12kN and gate should be properly closed and locked before use.

9. LIMITATIONS :

- Connector should be the personal property of its user.
- The equipment shall only be used by a person trained and competent in its safe use.
- The equipment shall not be used outside its limitation , or for any purpose other than for which it is intended.
- Anchor point should be positioned above the user's head to minimize potential fall hazards.
- Full body harness is the only acceptable body holding devices that can be used in a fall arrest system.

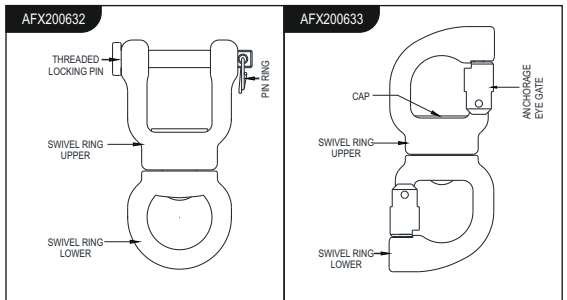

10. **INSTRUCTIONS FOR REPAIR:** If the product becomes damaged, it will NOT provide the optimum level of protection, and therefore it should be immediately replaced. Never use the damaged product.

11. WARNING:

- Do not make any alterations or additions to the equipment without the manufacturer's prior written consent and that any repair shall only be carried out in accordance with the manufacturer's procedures.
- Withdraw from use any connector for which any doubt arises about its condition for safe use or in the event, a fall has been arrested by it. It is essential for the safety of the user that if the product is re-sold outside the original country of destination the reseller shall provide instructions for use, maintenance, periodic examination and for repair in the language of the country in which the product is to be used.
- **Following conditions may be hazardous and may affect the performance of the equipment:**
 - Extreme temperature.
 - Trailing or looping of Lanyards over sharp edges.
 - Extreme acidic or basic environments.
 - Abrasive or sharp edge structures which can damage the equipment.
 - Pendulum falls.
 - When equipment become wet, either from being in use or when due to cleaning, it shall be allowed to dry naturally, and shall be kept away from direct heat.

12. **CLEANING:** In case of minor soiling, wipe the equipment with cotton cloth or a soft brush. Do not use any abrasive material. For intensive cleaning wash the connector in water at a temperature between 30° C to 60° C by using a neutral detergent (pH 7). The washing temperature should not exceed 60° C. Do not use acid or basic detergents.

13. **STORAGE AND TRANSPORT:** When not in use, store the equipment in a well-ventilated area away from heavily acidic or basic environment. Never place heavy items on top of it. Also ensure that the Connector is stored away from chemically hazardous environment. Preferably storage should be in a dry environment. Always use manufacturer's standard packaging during transportation to protect it from damage or moisture.

14. PERIODIC EXAMINATION:

- The equipment needs to be periodically examined because the safety of the user depends upon the continued efficiency and durability of the connector.
- It is important to examine it at least once in every 12 months.
- Periodic examination is to be conducted by a competent person and strictly in accordance with the manufacturer's periodic examination procedures and shall also include checking the legibility of the product markings.

The product is marked with:-

- (i) Identification of manufacturer.
- (ii) Type of product code.
- (iii) Norm Reference.
- (iv) Serial No.
- (v) The 'CE' mark showing that the product meets the requirements of the PPE Regulation (EU)2016/425
- (vi) Mfg. Date
- (vii) Read The Instruction Before Use.
- (viii) Minimum Breaking Strength

MARKING

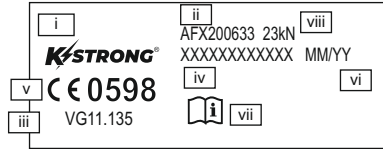

LIFESPAN: The estimated product Lifespan is 10 years from the date of manufacture. The following factors can reduce the Lifespan of the product: intense use, contact with chemical substances, specially aggressive environments, extreme temperature exposure, UV exposure, abrasions, cuts, violent impacts, bad use or maintenance.

DISCLAIMER: Prior to use, the end user must read and understand the manufacturer's instructions supplied with this product at the time of shipment and seek training from their employer's trained personnel on the proper usage of the product. Manufacturer is not liable or responsible for any loss, damage or injury caused or incurred by any person on grounds of improper usage or installation of this product.

EQUIPMENT RECORD				
Product				
Model & type/Identification		Trade Name		Identification number
Manufacturer		Address		Tel, email into use
Year of manufacture		Purchase Date		Date first put into use
Other relevant information (eg. document number)				
PERIODIC EXAMINATION AND REPAIR HISTORY				
Date	Reason for entry (periodic examination or repair)	Defects noted, repairs carried out and other relevant information	Name and signature of competent person	Periodic examination next due date

Certification Body :

SATRA Technology Europe Ltd, Bracetown Business Park, Clonee, Dublin D15 YN2P Ireland (Notified Body 2777)

Ongoing Assessment Body:

SGS Fimko Oy, Takomotie 8, FI-00380 Helsinki, Finland (Notified Body 0598)

For EU Declaration, please visit <https://kstrong.com/asia/eu-declaration-form/>



Kstrong Australia Pty Ltd

Unit 4-5 20 Lathe Place, Unanderra, New South Wales, Australia 2526

Contact Email: customercare@kstrong.com.au

www.kstrong.com

USA South America Asia Australia New Zealand

