



USER INSTRUCTION MANUAL  
**EXTREME DAVIT SYSTEMS**

THESE INSTRUCTIONS APPLY TO THE FOLLOWING MODELS:

AFT751010, AFT751011, AFT751020, AFT751021,  
AFT751030, AFT751031, AFT751050, AFT751040, AFT751041,  
AFT755014

**CE 0598**  
EN 795:2012



II 2G  
Ex h IIc T6 Gb  
EN 80079-36:2016  
EN 80079-37:2016

CERTIFIED PRODUCT



AUSTRALIA & NZ STANDARDS  
Certified to AS/NZS 5532:2013  
Issued by BSI  
Vide Lic. No.: BMP 760374

Please read and understand the manufacturer's instructions for each component or part of the complete system. Manufacturer's instructions must be followed for proper use, care, and maintenance of this product. These instructions must be retained and be kept available for the user's reference at all times. Alterations or misuse of this product, or failure to follow instructions, may result in serious injury or death.

**Note:** The user is advised to keep this user instructions document for the life of the product.

**"To be used in accordance with manufacturer's instructions"**

**1. INTRODUCTION:**

KStrong Extreme Davit are classed as a Personal Protective Equipment (PPE) by the European PPE Regulation (EU) 2016/425 and have been shown to comply with this Regulation through the Harmonized European Standard EN 795:2012 Type B For AFT751011, AFT755014. & EN795:2012 Type A for AFT751021, AFT751031, AFT751050 & AFT751041.

Davit arm are designed to minimize the risk of/provide protection against the danger of falling from heights. However, always remember that no item of PPE can provide full protection and care must always be taken while carrying out the risk related activity.

The KStrong Extreme Davit Systems are also certified to AS/NZS 5532:2013.

**2. PERFORMANCE AND LIMITATIONS OF USE:** AFT751011, AFT755014 has been tested as per EN 795: 2012 Type B & AFT751021, AFT751031, AFT751050 & AFT751041 has been tested as per EN 795:2012 Type A and has achieved the following performance levels:

EN 795: 2012 test	Result/Comment
General Requirements for Anchor devices (Clause 4.2)	Securely connected eyebolts used for connection to PPE. Thus attachment points cannot become detached unintentionally. (PASS). All locking pins attached by cables, thus no unlocked components evident (PASS). No sharp edges (PASS).
Static Strength (Clause 4. 4.2.3 )	Sustained a force of 12kN for 3 minutes (PASS).
Dynamic Performance (Clause 4. 4.2.2 ) & Integrity Test	When tested with rigid steel mass of 100 kg, the test mass held after test with the device remaining stable throughout. (PASS)
Corrosion Resistance (Clause 4.2.1.1)	No corrosion evident after 48 hours of salt spray testing. (PASS)

The Davit has been tested in accordance with AS/NZS 5532:2013 and have achieved the following performance levels-

AS/NZS 5532:2013 test	Result/Comment
Static Strength (Clause 5.3)	Sustained a force of 15 kN for 3 minutes (PASS).
Dynamic Performance (Clause 5.3)	When tested with rigid steel mass of 100 kg, the test mass held after test with the device remaining stable throughout. (PASS)

The KStrong Extreme Davit Systems meet or exceed ANSI Z359.1

MINIMUM MOUNTING REQUIREMENTS FOR DAVIT BASE:	
Moment Load for the structure	10kN (2238lbs)
Vertical Load for the structure	15kN (3372lbs)
<b>Structure resistance validation and installation execution must be performed by a certified person.</b>	

**3. LIMITATIONS:**

- Davit arm should be a personal property of its user.
- It should not be used in highly acidic or basic environment.

**4. APPLICATION & USE:** The KStrong Extreme Davit Systems have been designed for safe access into a variety of confined spaces, including Rope access and Jump Form rescue and evacuation. The UIM will cover the AFT751011, AFT751010 (H- Base Davit), AFT751021, AFT751020 (Floor Mount Davit), AFT751031, AFT751030 (Wall Mount Davit) and AFT751041, AFT751040 (Flush Mount Davit), AFT751050 (Hitch Mounting Davit ). The Extreme Davit Systems allow the Mast & Boom to be interchangeable across all of our Range which allows the user flexibility.

**3. INSTALLATION: AFT751011 / AFT751010- DAVIT H-BASE Installation**

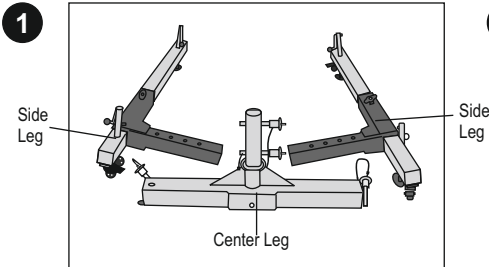

**STEP 1-** Place the Side Adjustable Assemblies & Column Base as shown in picture.

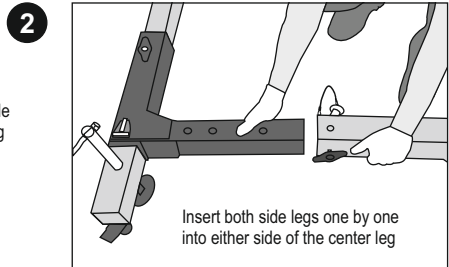

**STEP 2-** Attach both side legs with center leg by inserting them into each other.

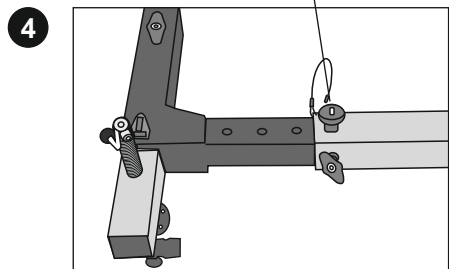
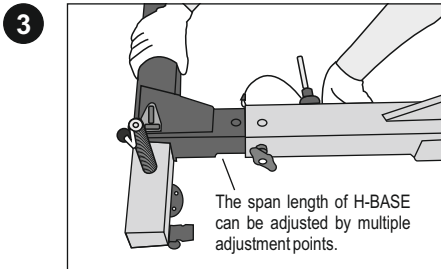

**STEP 3-** Lock the arms using the locking pin.

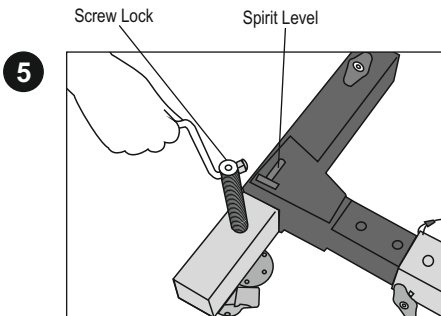

**STEP 4 -** Now stabilize the Davit on the flat surface by using Screw type height adjustment mechanism & provided Spirit level.

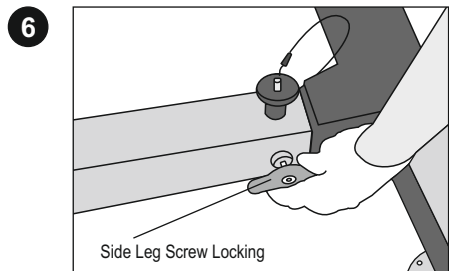

**Step 5 -**Tighten the side leg locking pin with provided screw and locking to minimize the play between legs.

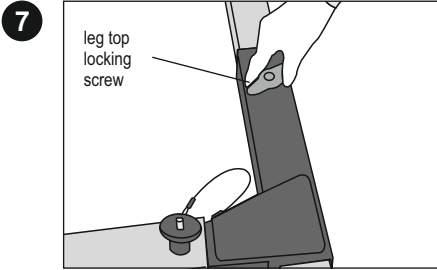

**STEP 6-** Tighten the leg top locking pin with provided screw locking to minimize the play between sections.

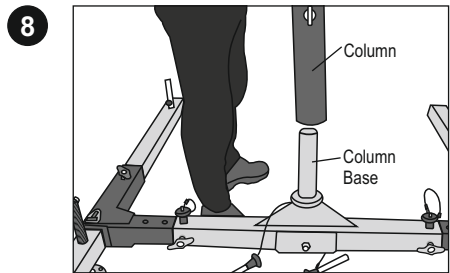

**Step 7 -** Now place the column on the Centre of column base as shown in picture.

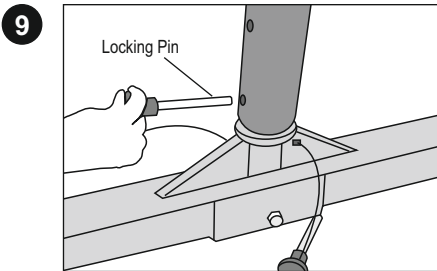

**STEP 8-** Lock the column leg on H-Base column using locking pin.

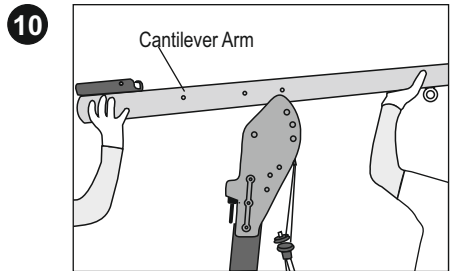

**STEP 9-** Place the cantilever arm on Column.

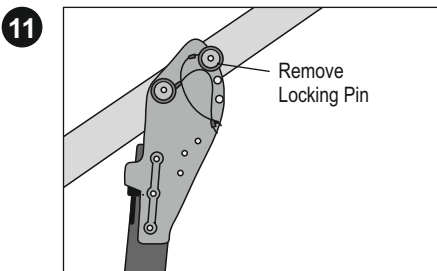

**STEP 10-** Insert the cantilever arm on the Column Assembly and lock it with locking pin. For adjusting cantilever arm on desired position please correct the sentence.

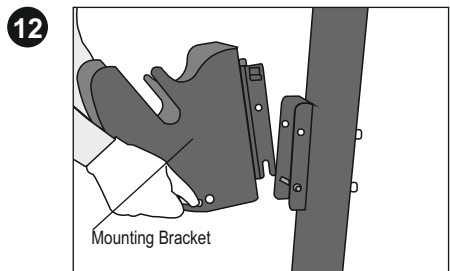

**STEP 11-** Place the mounting bracket on the pre-installed bracket on the Column of Davit.

**13**

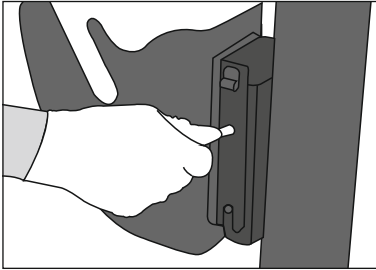

**STEP 11A**– Fix the mounting bracket on the Column Section Using Locking pins Secured by pins.

**14**

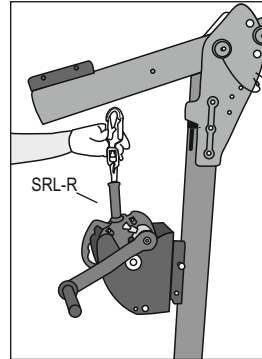

**Step 12**– Fix the SRL-R on the mounting bracket.

**15**

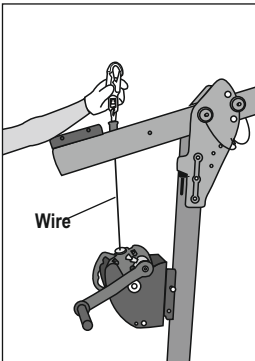

**STEP 13**– Reel out the wire from SRL-R by rotating the hoist handle and pass it through the pulley at the final end of cantilever arm.

**16**

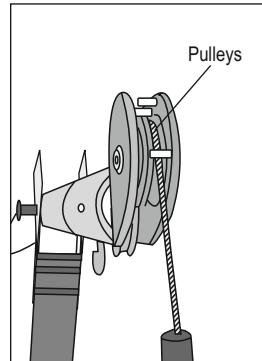

**17**

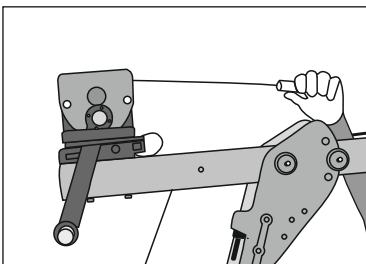

**Step 14**– Fix the Winch at initial end of the cantilever arm and reel out the wire from winch by rotating the hoist handle and pass it through the pulley at the final end of cantilever arm.

**18**

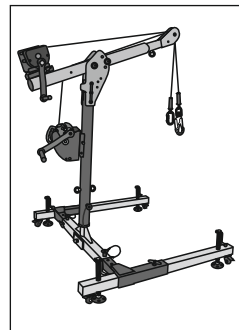

**STEP 15**– Davit Arm is now ready to use.

**Note:** Davit Arm can be shifted from one location to another as it comes with wheel and braking mechanism that enables easy movement.

Product Specification

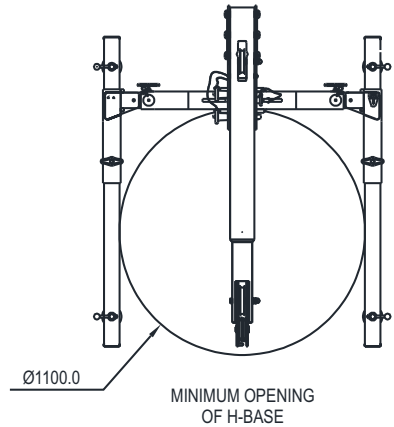
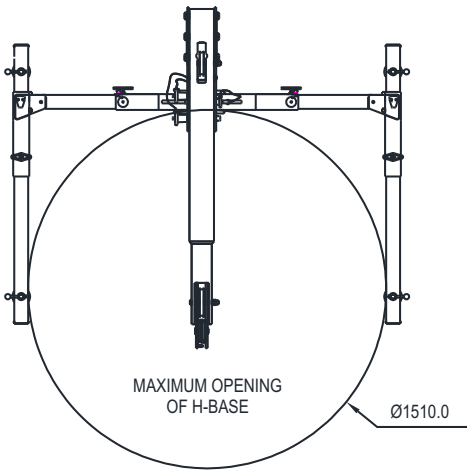
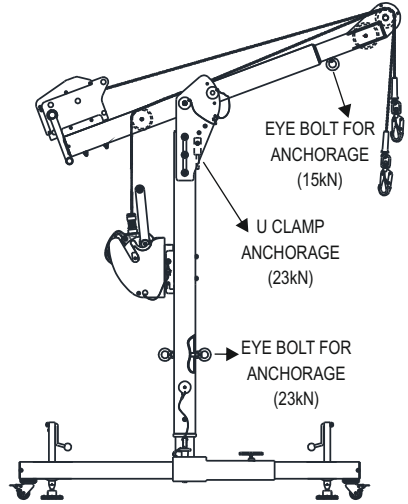
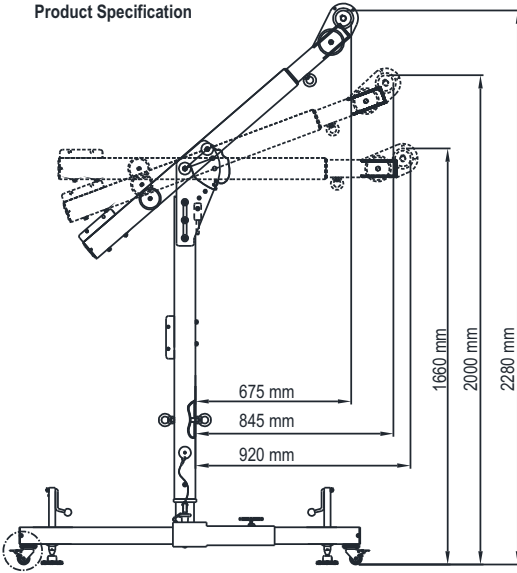

**AFT751021/AFT751020- Floor Mounted Davit Installation**



- Insert the Column in the Floor mounting AFT7500BF.
- Lock the Column with the Floor mounted base with locking pin.
- Repeat Step 9-14 to install brackets for winch and Rescue Retrieval SRL (Type 3)

AFT7500BF

Locking  
Pins

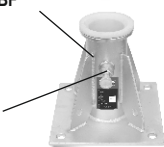

**AFT751030/AFT751031-Wall Mounted Davit Installation**



- Insert the column in the wall Mounted Base AFT7500BW
- Lock the column with the base with locking pin.
- Repeat Step 9-14 to install brackets for winch and Rescue Retrieval SRL (Type 3)

AFT7500BW

Locking  
Pins



**Installation requirements of Davit Floor & Wall Mount Base:**

**Structure** : The receiving structure must be able to withstand stresses equivalent to 22.1 MPa or 22.1N/mm<sup>2</sup>. The fasteners/structural anchors must be strong enough to handle this strain. Refer Fastener manufactures UIM for stainless steel/High tensile M16 fasteners.

**Floor Mount Base (AFT7500BF) are designed for mounting to concrete or steel structures.**

**Installation :**

- Thickness of concrete block should be minimum 9"(228.6mm)
- All receiving Structures should be verified by a qualified structural Engineer.
- Base Installation must be approved to local regulations by a qualified engineer.
- Refer to Fastener Manufacturer to ensure the correct fasteners are used.
- If the Base material does not meet the minimum requires to install, then reinforcement is required. Refer to a qualified engineer.
- Drill holes should have a minimum clearance of 11"(279.4mm) from all available edges
- If unsure, refer to a qualified engineer to recommend the location to mount the Floor mount base to the structure.
- Drill 4 holes using the base as a guide
- Install the recommended M16 fasteners and mount the base then tighten the bolts.
- Can also be installed on cantilever of concrete beam by sandwiching two plates on concrete structure
- Suitable M16 fasteners should be used for fixing the brackets to the structure.

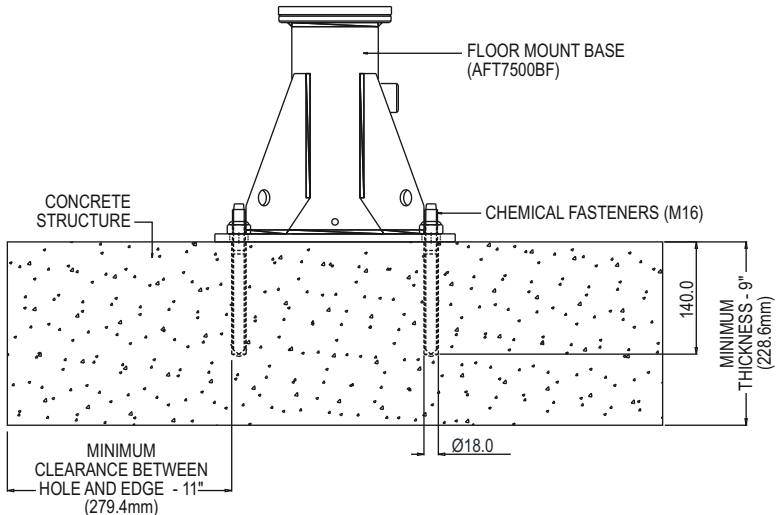
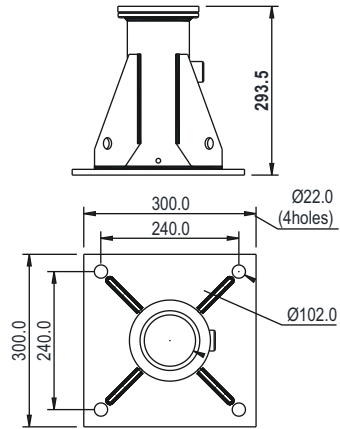

**WARNING** : Failure to follow User Instructions and Installation instructions may lead to severe injury and/or death.

**Wall Mount Base (AFT7500BW) are designed for mounting to concrete or steel structures.**

**Structure :** The receiving structure must be able to withstand stresses equivalent to 22.1 MPa or 22.1N/mm<sup>2</sup>. The fasteners/structural anchors must be strong enough to handle this strain. Refer Fastener manufactures UIM for stainless steel/High tensile M16 fasteners.

**Installation :**

- Thickness of concrete block should be minimum 9"(228.6mm)
- All receiving Structures should be verified by a qualified structural Engineer.
- Base Installation must be approved to local regulations by a qualified engineer.
- Refer to Fastener Manufacturer to ensure the correct fasteners are used.
- If the Base material does not meet the minimum requires to install, then reinforcement is required. Refer to a qualified engineer.
- Drill holes should have a minimum clearance of 11"(279.4mm) from all available edges
- If unsure, refer to a qualified engineer to recommend the location to mount the Floor mount base to the structure.
- Drill 4 holes using the base as a guide
- Install the recommended M16 fasteners and mount the base then tighten the bolts.
- Can also be installed on cantilever of concrete beam by sand-witching two plates on concrete structure
- Suitable M16 fasteners should be used for fixing the brackets to the structure.

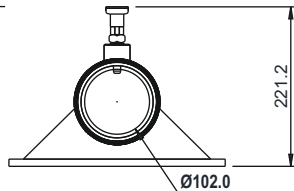
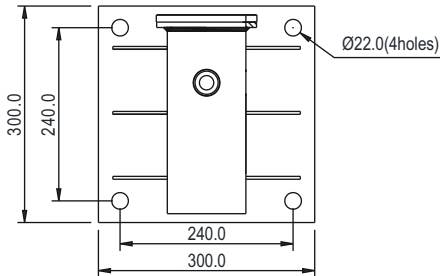
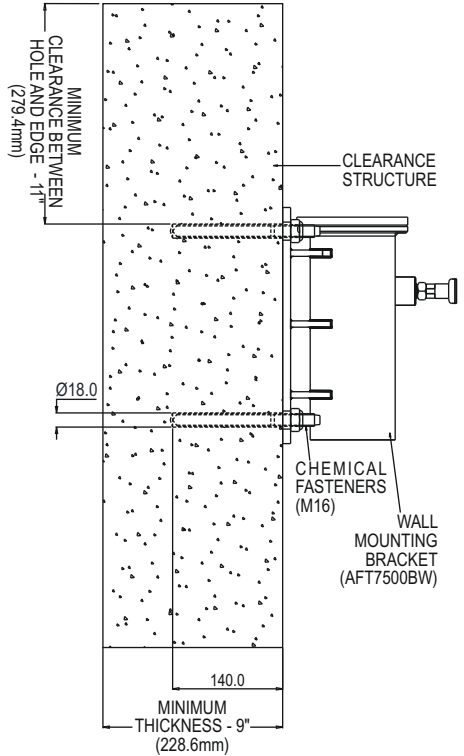

**WARNING :** Failure to follow User Instructions and Installation instructions may lead to severe injury and/or death.

**Product Specification**

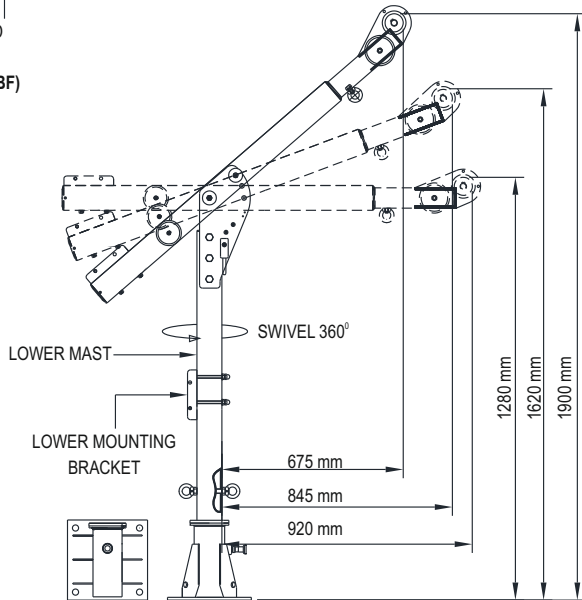
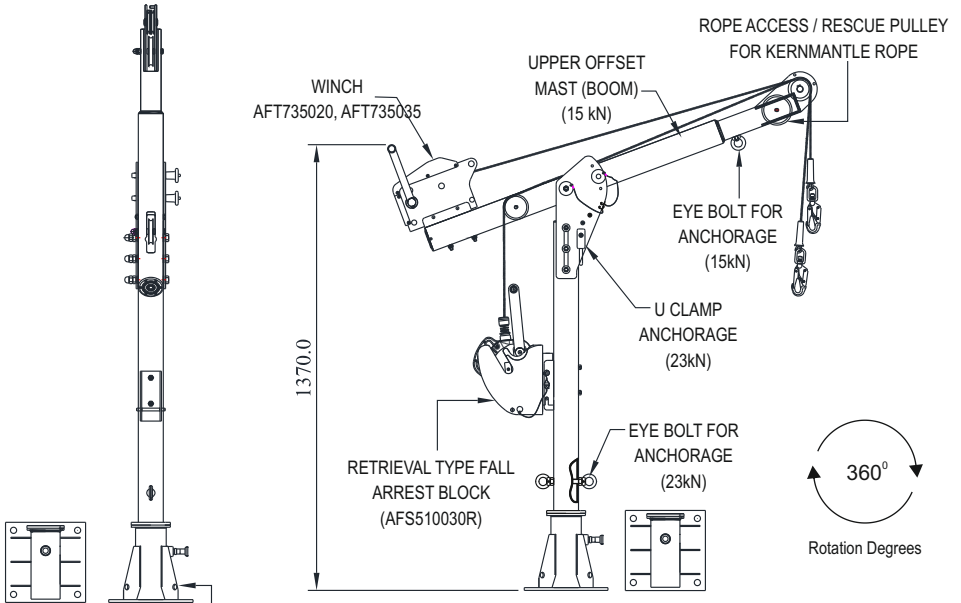

**AFT751040/AFT751041 -  
Flush Mounted Davit Installation**

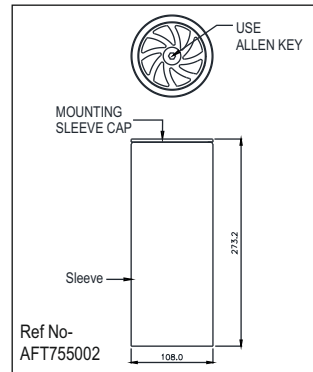
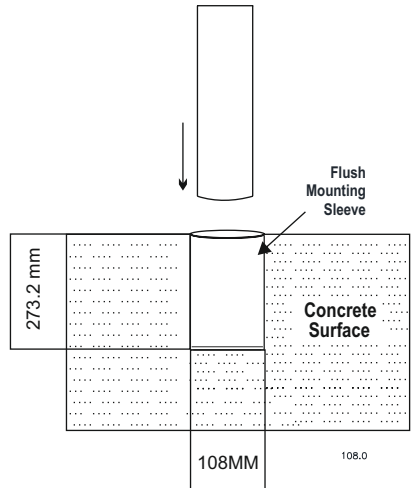

**INSTALLATION:**

Davit Flush Mounting sleeve can be installed at time of concrete structure being made & also can be installed in preformed concrete casting. To install the sleeve on preformed surface, make a drill hole of 112 mm dia. up to 274 mm deep. Also ensure to remove all the debris from hole & clean it properly, after that, Use all weather 400 epoxy or equivalent into hole to fix the sleeve.

Installation of mounting sleeve can be done during casting of the concrete by considering below requirements & subject to the condition that concrete should not ingress into the sleeve and sleeve should be properly flushed -

Structure strength- 14000 NM (Min.)

Thickness of concrete & distance from sleeve to edge should be duly checked & approved by a qualified structural engineer.

Installation of sleeve should be perpendicular to the concrete.

Repeat Step 9-14 to install brackets for winch and Rescue Retrieval SRL (Type 3)

**Note-** When flushed sleeve is not in use, apply socialized cap provided with assembly to prevent it from unwanted water/dust being stuck inside. Make the Allen screw loose with help of 6.0 mm Allen key for the opening of sleeve & when sleeve is not in use, insert the cap into sleeve and tighten the screw with help of 6.0mm allen key. **Base Installation must be approved to local regulations by a qualified engineer.**

### AFT751050 - Hitch Mounting Davit Installation

Make sure that the vehicle to be used with the Hitch Mounting Davit has a class 3 or higher vehicle trailer hitch. The class 3 trailer hitches mount to the vehicle frame and also has a 2 square receiving opening. Mid-size and larger SUVs, pickups, trucks, and vans have Class 3 trailer hitch.

**Note:** Minimum weight of Vehicle onto which Hitch Mounting Davit is to be installed should be 1000 kgs.

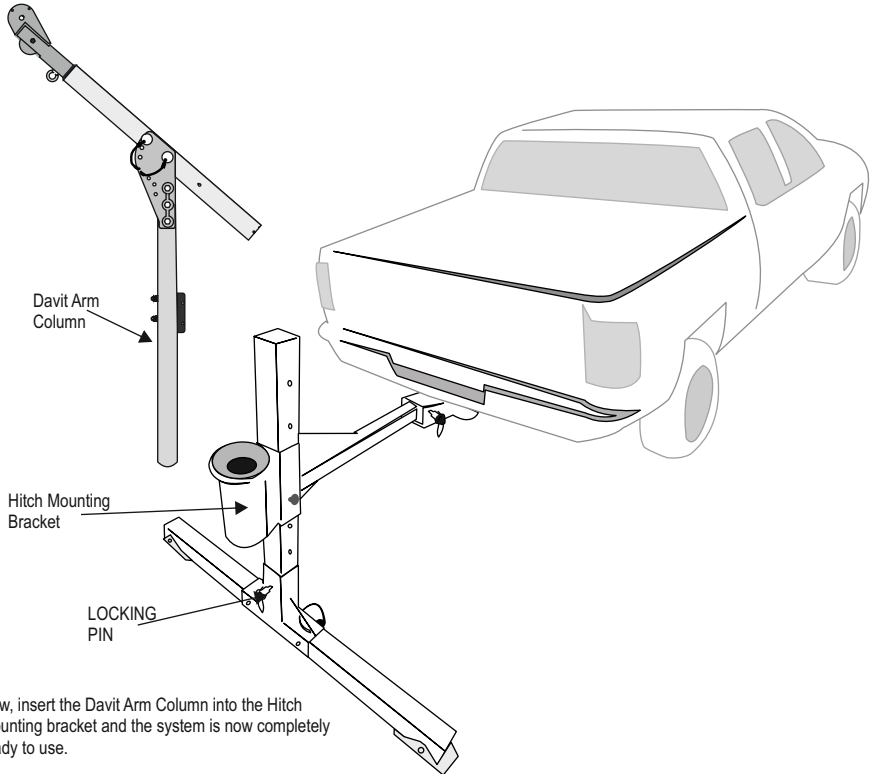

Now, insert the Davit Arm Column into the Hitch mounting bracket and the system is now completely ready to use.

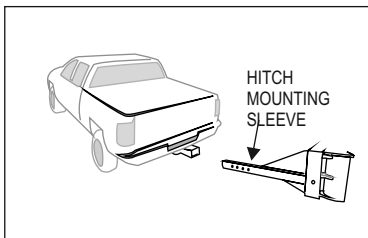
**1**

Place the vehicle on the selected location on the job site. Apply the parking brake and lock out/ tag out the vehicle.

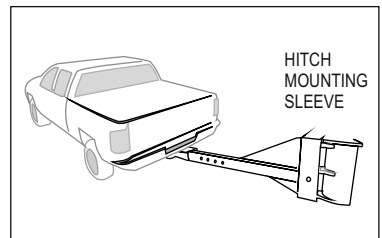
**2**

Now insert the Hitch mounting sleeve into the Class 3 hitch and, with Hitch Pin or Nut and bolt assembly help, secure it to the hitch receiver.

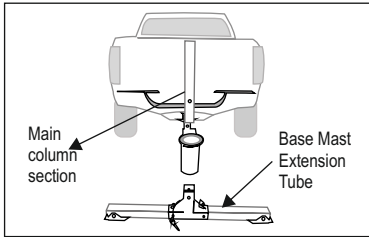
**3**

Insert the main column section into the hitch mounting sleeve then with the height adjustment tube align the base mast extension tube and insert the locking pin into it.

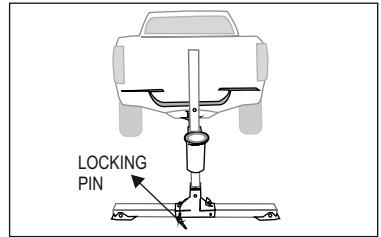
**4**

It is essential to check that the Hitch base mast extension tube is parallel to the ground. Ensure it by levelling the vehicle hitch mounting sleeve. Now select the appropriate hole of the hitch mounting sleeve and insert the locking pin into it.

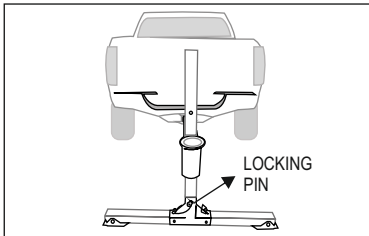
**5**

Insert the locking pins to lock Hitch base mast extension tube.

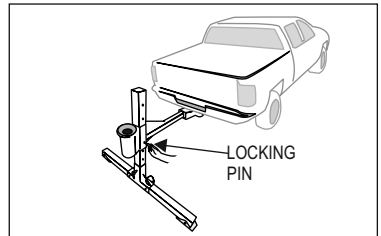
**6**

Now, place the davit arm onto the base mast extension tube. Make sure that the bolt on the lower mast extension tube fits the notch of the Davit Arm.

**AFT755014 - HOW TO INSTALL SHORING BARREL MOUNTING ADAPTER FOR DAVIT**

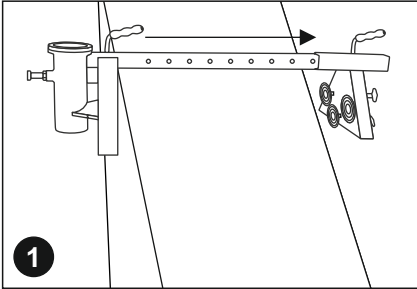

**1**

Place the anchor on the wall as indicated in the image.

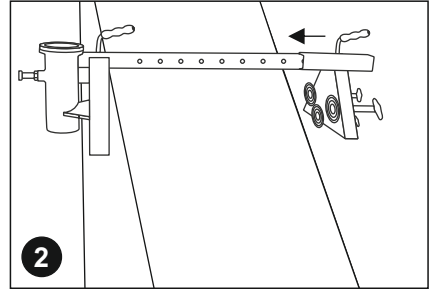

**2**

Slide the clamp closer to the wall and insert the locking pin into the nearest aligned hole.

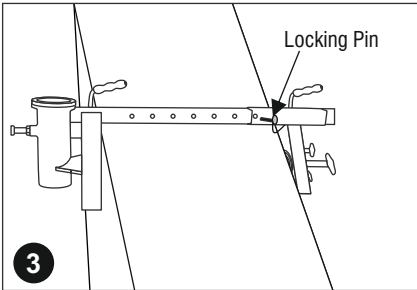

**3**

Lock the sliding clamp in position by inserting the locking pin.

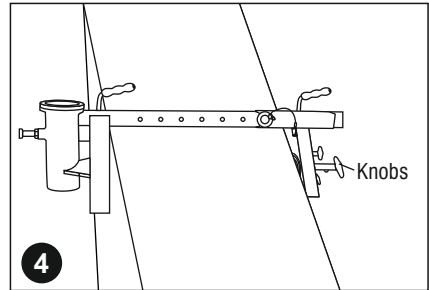

**4**

Twist the knobs on all three clamping screws to fasten the anchor to the wall. Make sure everything is stable by pressing down on the anchor.

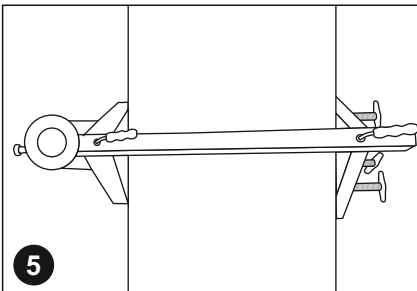

**5**

The anchor (AFT755014) is ready for use.



Now anchor is ready for use.

**5. ADVICE & INFORMATION:**

- Ensure that the medical condition of user does not affect his safety in normal and emergency use.
- Equipment shall only be used by a person trained and competent in its safe use.
- A rescue plan shall be in place to deal with any emergencies that could arise during the work.
- Do not make any alterations or additions to the equipment without the manufacturer's prior written consent, any repair shall only be carried out in accordance with manufacturer's procedures.
- The equipment shall not be used outside its limitation, or for any purpose other than that for which it is intended.
- It should be personal property of the user.
- Danger may arise by use of combination of items of equipment in which the safe function of any one item is affected by or interferes with the safe function of another.
- Visually inspect the system before each use to ensure that it is in a serviceable condition and is operating correctly. If during inspection, doubts are raised about the safety of the system or a component, these should be replaced either by the manufacturer or a competent person.
- It is essential for the safety of the user that the system should be withdrawn from service immediately if any doubt arises about its condition for its safe use. It must no longer be used until confirmed in writing by a competent person that it is safe to do so.
- Ensure the minimum breaking strength of the chosen anchor point is greater than 15kN.
- Ensure that the harness used conforms to EN361 and dorsal and sternal attachment of full body harness are suggested for making connections.
- For equipment intended for use in fall arrest systems, we emphasize that it is essential for safety that the anchor device or anchor point should always be positioned and the work carried out in such a way as to minimize both the potential for falls and potential fall distance. Where it is essential that the anchor device/point is placed above the position of the user, the manufacturer shall make a statement to that effect
- A full body harness is the only acceptable body holding device that can be used in a fall arrest system.
- For equipment intended for use in fall arrest systems, we emphasize that it is essential for safety to verify the free space required beneath the user at the workplace before each use, so that in case of a fall there will be no collision with the ground or other obstacle in the fall path.
- Always use standard packaging of the manufacturer to prevent any damage to the product during transportation and storage.
- Ensure that Equipment is properly installed on the surface parallel to horizontal by height adjuster mechanism.
- When equipment becomes wet either during use or by cleaning, it must be allowed to dry naturally and shall be kept away from direct heat. No lubrication required.
- Unit is for single user only.
- Anchor Device may be used only for personal fall arrest and not for lifting purpose.
- Anchor device should be installed by only by a competent person.
- It is essential for the safety of the user that if the product is resold outside the original country of destination, the reseller shall provide instruction for use, for maintenance, for periodic examination and for repair in the language of the country in which product in to be used.
- Never use the Davit Arm (Ref. AFT751011, AFT751010) device in a vertical configuration of the arm other than the all back position - danger of overturning of the device.
- **Following conditions may be hazardous & may affect the performance of Retractable Fall Arrester:-**
  - Extreme temperatures
  - Trailing or looping of Lanyards over sharp edges.
  - Extreme acidic or basic environments.
  - Abrasive or sharp edge structures which can damage the equipment.

**6. FOLLOWING PRE-USE CHECKPOINTS MUST BE ADDRESSED :-**

- Detent Pins are properly installed and are in working condition.
- Check the condition of winch wire is in good condition.
- Eye bolts/Anchor points are intact.
- Telescopic sections are working properly.
- Mounting brackets are properly installed.

7. **COMPATIBILITY:** To optimize protection, in some instances it may be necessary to use the equipment with suitable PPE such as boots/ gloves/ helmet/ ear defenders. In this case, before carrying out the risk-related activity, consult your supplier to ensure that all your protective products are compatible and suitable for your application.
8. **INSPECTION :** Visually inspect the system before each use to ensure that it is in a serviceable condition and is operating correctly. If during inspection, doubts are raised about the safety of the system or a component, these should be replaced either by the manufacturer or a competent person.
9. **STORAGE AND TRANSPORT :** When not in use, store the Davit in a well-ventilated area away from heavily acidic or basic environment. Never place heavy items on top of it. Also ensure that the Davit is stored away from chemically hazardous environment preferably storage should be in a dry environment.
10. **REPAIR :** If the product becomes damaged, it will NOT provide the optimum level of protection, and therefore should be immediately removed from service. Never use the damaged product. Repair is permitted, provided that it is either done by the manufacturer or a competent repair centre or individual approved by the manufacturer.
11. **CLEANING :** In case of minor soiling, wipe the Davit with cotton cloth or a soft brush. Do not use any abrasive material. For intensive cleaning wash the Davit in water at a temperature between 30°C to 60°C by using a neutral detergent (pH 0 7). The washing temperature should not exceed 60°C . Do not use acid or basic detergents.
12. **WITHDRAWAL FROM USE :** If the system has been used to arrest a fall, it should be removed from service and returned to the manufacturer or a competent repair centre for servicing and retesting.
13. **PERIODIC EXAMINATION**
  - It is important to conduct regular periodic examination of the product because the safety of the user depends upon the continued efficiency & durability of the product.
  - The frequency of examination should be at least once in a year however it can be more than once if legislation requires, or frequency of use is high or environmental conditions have an adverse effect on it eg excessive rain, sea side environment, excessive heat etc.
  - It is emphasized that the examination be conducted only by a competent person and strictly in accordance with the manufacturer's periodic examination procedures.
  - It is also advised the competent person be duly trained and authorized by the manufacturer.
  - Ensure that all markings on the product are legible and can be clearly read.
  - It is the responsibility of the user to keep the below record card update by entering the details mentioned in it.





**Certification Body & Ongoing Assessment Body-**  
BSI Group ANZ Pty Limited, A.B.N. 72 078 659 211, Suite 2, Level 7, 15 Talavera Road, Macquarie Park NSW 2113 Australia

**Certification Body-**  
SATRA Technology Europe Ltd, Bracetown Business Park, Clonee, Dublin D15 YN2P Ireland (Notified Body 2777)  
**Ongoing Assessment Body -**  
SGS Fimko Oy, Takomotie 8, FI-00380 Helsinki, Finland (Notified Body 0598)



**KStrong Australia Pty Ltd**  
Unit 4-5 20 Lathe Place, Unanderra, New South Wales, Australia 2526  
Contact Email: [customercare@kstrong.com.au](mailto:customercare@kstrong.com.au)

[www.kstrong.com](http://www.kstrong.com)

---

USA	South America	Asia	Australia	New Zealand
-----	---------------	------	-----------	-------------

---

**KS GROUP**