

USER INSTRUCTION MANUAL
EDGE ANCHORS

THESE INSTRUCTIONS APPLY TO THE FOLLOWING MODELS:

AFA930316, AFA930316C



CERTIFIED PRODUCT



AUSTRALIA & NZ STANDARDS
Certified to AS/NZS 5532:2013
Issued by BSI
Vide Lic. No.: BMP 760374

EN 795:2012 Type A



This manufacturer's user instruction manual meets the requirements of ANSI Z359.18-2017. As per OSHA, this manual should be used as a part of an employee training program.

▲ WARNING

The products enumerated in this instruction manual are a part of a personal protective, work support or rescue system. It is important that the user reads and follows the manufacturer's instructions for each component of the system. This manual contains information which is important to the user's safety and should be kept in a safe place for future reference as needed. Please contact KStrong for any questions regarding use of this equipment.

Fall arrest systems and equipment are life saving products and are designed to reduce the potential of serious injury in the event of a fall. However, it is important to note that the user may experience an impact of force on their body in the event of a fall. . In case there is a doubt about the user's ability to utilize this product, the user must consult a physician. Pregnant women and minors are not considered fit for the use of this equipment.

TRAINING

In order to ensure that the user is familiar with the instructions provided in this manual, it becomes the responsibility of the employer and user to undergo training in proper inspection, use and maintenance of this equipment.

TECHNICAL SPECIFICATIONS

Model. No.	Product Name	Minimum Breaking System	Material of Construction
AFA930316	Swivel Anchor with Nut Bolt	44kN / 10000 lbs.	Galvanized Steel
AFA930316C	Swivel Anchor		Galvanized Steel

IMPORTANT INFORMATION

- It is important to inspect the equipment according to the manufacturer's instructions before each use.
- Inspection of equipment should be done on a regular basis by a qualified person and the results should be recorded in the inspection log.
- DO NOT REMOVE product labels which include important warnings and information for the "Authorized Person".
- "Authorized Person" is a person who is exposed to fall hazards during the course of their work. This individual requires formal training in the use of personal fall protection equipment and systems. The term "Authorized Person" may be used interchangeably with "User" and "End-User".
- DO NOT ALTER the equipment in any way.
- Always send the equipment back to the manufacturer, or to the persons or entities authorized in writing by the manufacturer, for any repairs if required.
- Never use any natural material like manila, cotton, etc. as part of the Fall Protection System.
- Fall protection equipment should only be used for the purpose for which it has been designed.
- This equipment should never be used for towing and hoisting or for any other purpose than its intended use.
- A competent person must ensure compatibility of the system to minimize any potential for accidental disengagement.
- Authorized persons or users shall be trained on all warnings and instructions provided in this manual.
- It is important for all authorized persons and users to refer to the applicable AS/NZS Standards and to the regulations governing occupational safety.
- Take proper precautions to remove any debris, material, obstructions, etc., from the work area which could cause injury, or otherwise interfere with the functioning of the system.
- KStrong Anchors should be used only with the combinations of components, sub-systems or both which may affect or interfere with the safe function of one another. Be certain that connecting devices are compatible and that other elements of the PFAS are safe and compatible before use.
- Always check for obstructions below the work area to make sure that the potential fall path is clear.
- Keep the equipment away from anything that could damage it such as sharp edges, rough or abrasive surfaces, high temperature surfaces, heat and welding sources, moving machinery, electrical hazards, etc.
- It is important to keep in mind environmental hazards when selecting fall protection equipment.
- Do not expose the equipment to chemicals, highly corrosive or caustic environments, or to direct sunlight and UV radiation, which may cause UV degradation.
- Such harmful environments require a more frequent inspection and servicing program of the fall protection equipment to maintain the integrity and safety of the equipment. Contact KStrong if in doubt.
- All the synthetic material of fall protection equipment must be protected from slag, hot sparks, open flames or other heat sources.
- It is recommended that heat resistant materials are used in such applications. It is important to allow adequate fall clearance below the work surface.
- Always have a Rescue Plan ready and at hand when using this equipment.

▲ WARNING

- Immediately discard any product which is exhibiting unusual wear, deformity or deterioration.
- Immediately remove from service any equipment that has been subjected to a fall.

COMPONENT COMPATIBILITY

Component compatibility with KStrong manufactured fall protection equipment is ensured by strictly following the instructions for each type of equipment used. However, if the user utilizes combinations of components or sub systems that are manufactured by others, only a "qualified" or "competent" person (as defined in OSHA) can ensure the compatibility. If substitutions or replacements are made with non-approved components or sub systems, then this may severely affect the compatibility of the equipment, making the complete system unsafe for use.

COMPATIBILITY OF CONNECTORS

To ensure the compatibility of the connectors with their connecting element, it is important to safeguard that the sizes and shapes of the connectors and the connecting elements do not allow their gate mechanisms to open inadvertently, notwithstanding their orientation with each other. All hooks, Karabiners, D-rings and other such connectors must be capable of supporting a min. force of 5000 lbs. (23 kN). All connectors must be compatible with all system components like anchorages, etc. Never use equipment which is not compatible as this may cause the connectors to disengage unintentionally. All connectors must be compatible in shape and size. As per ANSI Z359.12 / AS/NZS Standard and OSHA, only self-locking snap hooks and Karabiners may be used.

CONNECTIONS USING CONNECTORS

Ensure that only self-locking snap hooks and Karabiners are used with this equipment. All connections should be compatible in size, shape and strength. The connectors used should be suitable to each application. Ensure that they are fully closed and locked while in use.

NEVER USE INAPPROPRIATE CONNECTIONS

While using KStrong snap hooks and Karabiners, they should not be connected as below:

- Two or more connectors should never be attached to a single D-ring.
- Never attach a connector that could result in a load on its gate.
- Connectors should not be connected in a false engagement. It should be visually confirmed that the connector is fully engaged to the anchor point. Avoid conditions that allow for features that protrude from the connectors to catch on the anchor, giving a false sense of being connected.
- Connectors should not be connected to each other.
- Connectors should not be connected directly to the webbing or to the rope lanyard or tie back, unless specifically allowed by the manufacturer.
- Connectors should not be connected to any object which does not allow the connector gate to close or lock. Anchor shapes that allow roll out to occur should never be used for connection. If the anchor, to which the snap hook or Karabiner is attached, is under sized or irregular in shape, then this may allow for the gate of the connector to come in contact with the anchor, thereby causing the connector to open up and possibly disengage from the anchor. This is known as roll out of the connector.

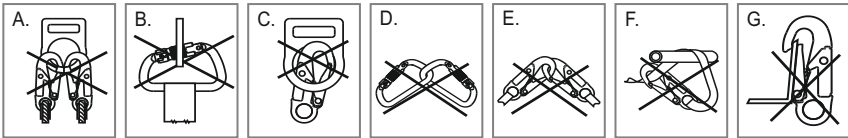

- Do not use connectors on an anchorage object as shown in figure A to G.

▲ WARNING

Large throat opening snap hooks should not be connected to standard size D-rings or similar objects. The reason for this is if the hook or D-ring twists or rotates, then this may result in a load on the gate of the connector. Large throat snap hooks are specifically designed for use on fixed structure elements such as rebar or cross members. These are shaped in such a way that they cannot capture the gate of the hook.

IMPORTANT RESTRICTIONS WHILE MAKING CONNECTIONS

- A snap hook should not be connected into a loop or thimble of a wire rope, or attached to it in any way that may slack the wire rope.
- Do not make connections where the connector locking mechanism can come into contact with a structural member, or other such equipment, as it may potentially unlock the connector and release the connection.
- To connect to a single or a pair of soft loops on a harness, a Karabiner that can fully close and lock should only be used. Snap hooks are not allowed for such connections.
- A Karabiner may be connected to a loop or ring connector that is already occupied by a choker style connector. Snap hooks are not allowed for such connections.

If the connecting element to which a snap hook (shown) or Karabiner attaches is undersized or irregular in shape, a situation could occur where the connecting element applies a force to the gate of the snap hook or Karabiner. This force may cause the gate (of either a self-locking or a non-locking snap hook) to open, allowing the snap hook or Karabiner to disengage from the connecting point.

Small ring or other non-compatibly shaped element

1. Force is applied to the snap hook.



2. The gate presses against the connecting Ring.



3. The gate opens allowing the snap hook to slip off.



CONNECTING SUBSYSTEMS

Use only those connecting subsystems (self-retracting lifeline, lanyard, rope grab and lifeline, cable sleeves) that are suitable for your application. See subsystems manufacturer's instructions for more information. Some harness models have web loop connecting points. Do not use snap hooks to connect to the web loop. Use a self-locking Karabiner to connect to a web loop. Ensure that the Karabiner is connected in such a way that it does not lead to cross-gate load. Sometimes lanyards may be sewn directly to the web loop forming a permanent connection. Do not make multiple connections onto one web loop.

RESCUE PLAN

A rescue plan should be well documented and in place before performing work at height. The rescue operation must be performed by trained and competent personnel only. The rescue expert team should supervise the rescue operation performed. It is also advised to work in pairs while working on site.

ENVIRONMENTAL HAZARDS

It is important to take additional precautions while using this equipment in the presence of any environmental hazards so as to prevent injury to the user or damage to the equipment.

Environmental hazards may include the following, but are not limited to:

- Chemicals
- Extreme Temperatures
- Corrosive Environments
- Gases
- High Voltage Power Lines
- Sharp Edges
- Moving Machinery and Vehicles

Please contact KStrong for use of this equipment in the presence of any environmental hazard.

⚠ WARNING

This equipment is not designed to be used in high temperature environment. It is important to protect this equipment when using near activities like welding or metal cutting. Hot sparks may cause damage to this equipment or burn it. Contact KStrong with any questions regarding the details on use of this equipment in high temperature environment.

ANCHORAGE STRENGTH

The application type determines the anchorage strength requirement. As per ANSI Z359.1 / AS/NZS 5532:2013 the necessary anchorage strength for the following applications is listed below:

- **Fall Arrest:** As per OSHA 1926.500 and 1910.66: anchorages that are used for attachment of Personal Fall Arrest Systems (PFAS) shall be independent of any anchorage being used to support or suspend platforms. They should be capable of withstanding a minimum load of 5000 lbs. (23 kN) per user attached, or should be designed, installed and used as part of a complete PFAS which maintains a safety factor of at least two. Rating of the anchorage should always be done under the supervision of a qualified person.
- **Work Positioning:** The structure to which the work positioning system (WPS) is attached must be able to sustain a static load of min. 3000 lbs. (13.3 kN), applied in the directions permitted by the work positioning system. Or, it should be able to sustain two times the potential impact load, whichever is greater; see 1926.502. However, if more than one work positioning system is attached to an anchorage, then the strength mentioned above must be multiplied by the number of WPS attached to the anchorage.

- **Restraint:** The strength requirement of anchorages which are selected for restraint and travel restraint systems is min. of 1000 lbs. (4.5 kN) static load applied in the directions permitted by the system. If more than one restraint and travel restraint system is attached to anchorage, then the 1000 lbs. shall be multiplied by the number of systems attached to the anchorage to determine the min. strength requirement.
- **Rescue:** The minimum strength of the anchorage selected for rescue should be such that it is capable of sustaining a static load of min. 3000 lbs. (13.3 kN) applied in the direction permitted by the system. To determine the strength requirement of the anchorage if more than one rescue system is attached, then multiply 3000 lbs. (13.3 kN) by the number of the systems attached to the anchorage.

GENERAL LIMITATIONS OF FALL ARREST SYSTEM AND REQUIREMENTS

It is important to consider the below mentioned limitations before using or installing this equipment:-

- The **capacity** of the KStrong full body harness is up to 310 lbs. (140 kg) hence, the combined weight (clothes, tools, shoes etc.) of a person using these harnesses should not be more than 310 lbs. It is important to ensure that all the components in the system are rated to a capacity which is appropriate to the application.
- **Free Fall:** As per ANSI Z359.11 / AS/NZS 1891.1 the personal fall arrest systems used with this equipment must be rigged in such a way that the free fall does not exceed 6 ft. (1.8 m). Restraint systems must be rigged in such a way that no vertical free fall is possible. Work positioning systems are required to be rigged in a way that the free fall does not exceed 2 ft. (0.6 m). Personal riding systems must be rigged so that there is no vertical free fall possible. Climbing systems must be rigged so that free fall is less than 18 inches (46 cm). Rescue systems must be rigged in such a way that there is no vertical free fall. Contact KStrong for any further information needed.
- **Fall Clearance:** There should be sufficient clearance below the user to allow the system to arrest a fall so as to prevent the user from striking the ground or any other obstruction. The clearance required depends upon the following factors:
 - Harness Stretch - $H_2 = H_1 - H_1$ (Harness stretch should be \leq (less than equal to) 18 inches)
 - Anchorage location
 - Type of connecting subsystem used (energy absorbing lanyard, self retracting lifeline (SRL), etc.)

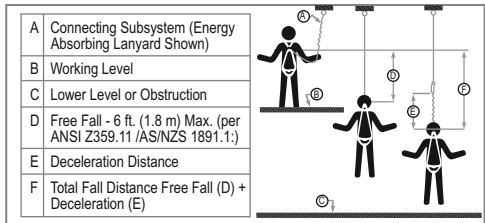

If the only available anchorage is situated below the attachment on the harness; and if there is a risk of fall, then it is essential to use a lanyard with a properly rated energy absorber. It is important to ensure that there is sufficient fall clearance below the user, before using a shock absorbing lanyard. If the weight of the wearer is 220 lbs. and the fall factor is two, we can calculate the fall clearance (which will be equal to the stopping distance $H(2L + 5.74 \text{ ft.})$ + an additional distance of 3.28 ft.).

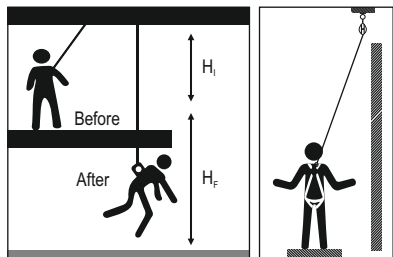

Calculating Total Fall Distances:

Total Fall Clearance below worker is calculated from Anchorage Connection. Free Fall Distance + Energy Absorber Deceleration Distance + Worker height + Safety Factor. Care must be taken to ensure that the total fall distance is clear of obstructions; such as equipment, to avoid contact with a lower level.

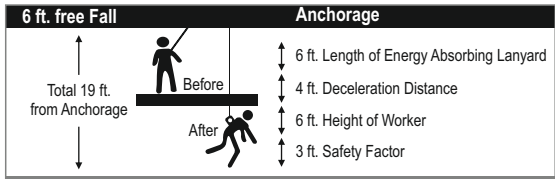

Free Fall Distance + Energy Absorber Deceleration Distance + Worker height + Safety Factor = 19 ft. (5.8 m)

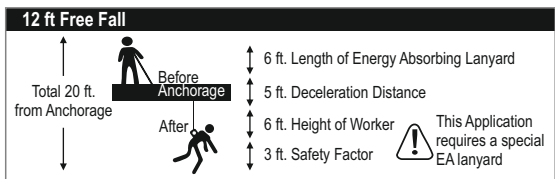

Free Fall Distance + Energy Absorber Deceleration Distance + Worker height + Safety Factor = 20 ft. (6.1 m)

- **Swing Falls:** Swing fall occurs when the position of the anchorage point is not directly above the point where a fall occurs. In such a case, if a fall were to occur, it will result in a pendulum swing of the fall victim and may also cause them to strike nearby objects with force. This may cause serious injury or even death. Such swing falls may be minimized by ensuring that the anchorage is directly overhead, and by working as close to the anchorage point as possible. Swing falls will substantially increase the fall clearance required when a SRL or other variable length connecting subsystem is used.
- **Extended Suspension:** Using a full-body harness: AFBH is not intended for use in extended suspension applications. If the user is going to be suspended for an extended length of time, it is recommended that some form of a seat support be used. KStrong recommends a seatboard, suspension work seat, seat sling, or a boatswain chair. Contact KStrong for more information on these items.
- **Periodic Examination:** Always keep the instructions provided with the product. Take the information from the markings on the product and enter this information on the identification sheet. To ensure the safety of the user, it is essential to check the condition of the equipment through periodic examinations of the product. This equipment must be examined by a qualified person at least once in six months, strictly complying with the manufacturer's instructions. Also, record the previous check on the attached sheet. If the equipment is in heavy usage or is used in a harsh environment, then the frequency of inspection should be increased in accordance with regulations. Also, check that the markings on the product are legible.

SPECIFIC INSTRUCTIONS

Kstrong Anchors are designed to provide a complete attachment system to the user in the event of a fall. These attachment systems must be connected to proper body support and connecting facilities. These Anchors are meant to hold the victim off fall until the rescue operation is performed, so it is important that the whole system must have all the essential components before use. The entire fall arrest system must be used by a trained/competent person. It is advisable to make a checklist of the essential components according to one's use before commencing work.

USE OF FALL ARREST SYSTEM

The fall arrest system **MUST ONLY** be connected to the back attachment element on the harness provided for the purpose ("D" ring or webbing attachment extension) or to the chest anchorage points ("webbing link" or "D" link). The chest anchorage points must imperatively be used together. The D-rings on the belt and the ventral anchorage point must only be used for the attachment of a work positioning or retaining system and never with a fall arrest system. During use, regularly check the adjustment and/or attachment points.

INSPECTION

Before each use, proceed with a thorough visual examination to ensure that the PPE is intact (the same applies to the equipment used with the harness (connectors, lanyard, etc.) and take all necessary steps concerning the implementation of rescue in total safety. In the event of your product being contaminated, consult the manufacturer or authorized agent. If you have any doubts regarding the safe state of the product or if the product has been used to arrest a fall, for your personal safety, it is essential to withdraw the PPE from service and send it back to the manufacturer or a qualified repair center for checking or destruction.

Before each use of this equipment, inspect it according to the following guidelines: A formal inspection of fall protection products/components must be performed at least every six months by a competent person other than the user. The frequency of formal inspections should be based on conditions of use or exposure. Record the inspection results in the inspection and maintenance log at the end of this manual. The component should be checked for cuts, frays, heavy soiling, welding burns, etc. Metal parts like D-rings should be duly checked for cracks, bends, deformities, corrosion, etc.

Following the inspection, the center will provide written authorization or refusal for the use of the PPE. Never attempt to modify or repair PPE.

Instructions for Installation of Swivel Anchor Post (AFA930316, AFA930316C)

The Swivel Anchor Post is designed to function as an interface between the anchorage and fall protection, work positioning, rope access, or rescue system. This serves the purpose of coupling the system to the anchorage. Any references to "anchorage connector" in this manual include, and apply to, the Swivel Anchor Post.

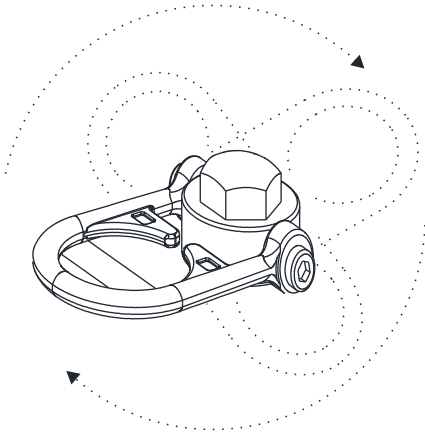

Working load: 1000 lbs (453 kgs)
 Can be used with Horizontal Life Line Systems
 Weight: 1.2-lbs (544.31g)
 Materials: Zinc plated steel

AFA930316C

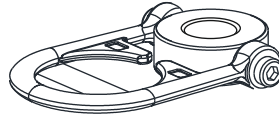

AFA930316

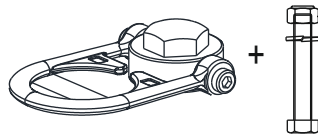

To be installed on metal structure & Comes with 5/8" – 4" long hex head bolt along with washer & nut

UFA30311

- A bolt no shorter than 4' (100mm) with a grade 5-8 (or equivalent) with a locking nut and washer must be used for all steel applications. A swivel anchor must be flushed with steel surface. For all metric applications a 16mm bolt may be used in place of 5/8"-16.

Torque Range: 75-90 ft-lbs (100-120Nm)

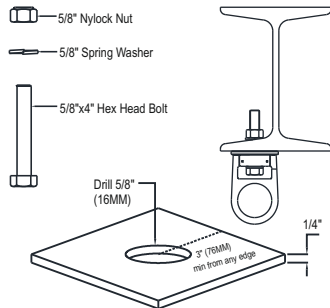

AFA930316C

- Use a proper drill & bit for concrete. (SDS drill bit)
- Drill a 3/4" (19mm) hole no less than 5" (127mm) deep 9" (229mm) away from any edge.
- Hole must be straight & perpendicular to surface.
- Hole must be free of debris
- Use Mechanical Fastener Sleeve anchor Make HILTI HLC-H 16x140/90 #385855 to install AFA930316C.
- Concrete strength must be at least 3000psi (20.7MPa) and no less than 7" (178mm) thick.

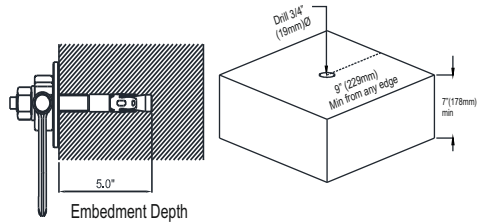

Torque Range: 3-5 full turns beyond hand tight

Direction of Loading			
<p>Correct</p>	<p>Correct</p>	<p>Correct</p>	<p>Incorrect</p>

ANCHORAGE STRENGTH : The Anchorage strength required depends on the application type. Following are the requirements of ANSI 359.1 for these application types:-

- **Anchorage & anchorage strength** : Anchorage and anchorage strength requirements are dependent on the full body harness application. In accordance with ANSI Z359.1, anchorages selected for fall Arrest Systems must meet the anchorage strength requirements defined in below Table.

Table - Anchorage Strength Requirements		
Fall Arrest ¹	Non-Certified Anchorage:	5000 lbs. (23 kN)
	Certified Anchorage ² :	2 Times the Maximum Arresting Force for Certified Anchorage
Restraint ¹	Non-Certified Anchorage	1,000 (4.5 kN)
	Certified Anchorages ² :	2 times the foreseeable force for certified anchorages.
Work Positioning ¹	Non-Certified Anchorages	3,000 lbs (13.3 kN)
	Certified Anchorage ² :	2 times the foreseeable force for certified anchorage.
Rescue ¹	Non-Certified Anchorage	3,000 lbs (13.3 kN)
	Certified Anchorage ² :	5 times the foreseeable force for certified anchorage.
Climbing	The structure which a climbing system is attached must sustain the loads required by that particular system. See the instructions for the climbing system for requirements.	
<p>1 Multiple Systems: When more than one of the defined system is attached to an anchorage, the strength defined for Non-Certified or certified anchorage shall be multiplied by the number of systems attached to the anchorage.</p> <p>2 Certified Anchorage: An anchorage for fall arrest, positioning, restraint, or rescue systems that a qualified person certifies to be capable of supporting the potential fall force that meet the criteria for a certified anchorage prescribed in this standard.</p>		

- **Field Serviceability Testing** - It is not required and also not recommended to perform this testing by the End user.
- **Fall Arrest:** Anchorages selected for fall arrest systems shall have a strength capable of sustaining static loads applied in the directions permitted by the system of at least: 1. 5000 lbs. (23 kN) for non-certified anchorages, or 2. Two times the maximum arresting force for certified anchorages. When more than one fall arrest system is attached to an anchorage, the strengths set forth in (1) and (2) above shall be multiplied by the number of systems attached to the anchorage.
- **As Per OSHA:** Anchorages used for attachment of personal fall arrest systems shall be independent of any anchorage being used to support or suspend platforms and capable of supporting at least 5,000 lbs.(23 kN) per user attached, or be designed, installed and used as part of a complete PFAS which maintains a safety factor of at least two, and is under the supervision of a qualified person.
- **Work Positioning:** The structure to which the work positioning system is attached must sustain static loads applied in the directions permitted by the work positioning system of at least 3,000 lbs., or twice the potential impact load, whichever is greater. See OSHA. When more than one work positioning system is attached to an anchorage, the strengths stated above must be multiplied by the number of work positioning systems attached to the anchorage.
- **Restraint:** Anchorages selected for restraint and travel restraint systems shall have a strength capable of sustaining static loads applied in the directions permitted by the system of at least: 1. 1,000 lbs. (4.5 kN) for non-certified anchorages, or 2. Two times the foreseeable force for certified anchorages. When more than one restraint and travel restraint system is attached to an anchorage, the strengths set forth in (1) and (2) above shall be multiplied by the number of systems attached to the anchorage.
- **Rescue:** Anchorages selected for restraint and travel restraint systems shall have a strength capable of sustaining static loads applied in the directions permitted by the system of at least: 1. 3,000 lbs. (13.3 kN) for non-certified anchorages, or 2. Five times the foreseeable force for certified anchorages. When more than one restraint and travel restraint system is attached to an anchorage, the strengths set forth in (1) and (2) above shall be multiplied by the number of systems attached to the anchorage.
- **Fall clearance :** If there is a risk of fall or if the only anchorage is below the attachment points on the harness, it is essential to use a lanyard provided with an energy absorber. Before using a shock-absorbing lanyard, check that there is sufficient fall clearance below the user to prevent any collision with the structure or the ground.

PERIODIC EXAMINATION:

Keep these instructions with the product and fill in the identification sheet, entering the information taken from the markings

- The periodic examination is essential to test the resistance and condition of the equipment and to guarantee the safety of the user.
- A qualified person must examine this equipment at least once each year in strict compliance with the instructions of the manufacturer and the previous check must be recorded on the attached sheet.
- The frequency of inspection should be increased in accordance with the regulations, if the equipment is in heavy usage or if the equipment is used in harsh environments. Also Check that the markings are legible.

SYSTEM REQUIREMENTS:

- **Compatibility of Components:** KStrong Fall Protection equipment is designed to be used with KStrong approved components. Please contact KStrong if you have a question regarding compatibility. Making substitutions without approval from KStrong Fall Protection may lead to injuries and or death by compromising the safety and reliability of the complete system. A Qualified person can make a determination on compatibility of equipment from different manufacturers.
- **Compatibility of Connectors:** Connectors (D-rings, hooks, Karabiners) must be capable of supporting at least 5000 lbs. (23 kN). Do not use equipment that is not compatible. Non-compatible connectors may unintentionally disengage. Self-locking snap hooks and Karabiners are required by CSA, ANSI, AS/NZS and OSHA. Connectors must be compatible in size, shape, and strength.
- **Making Connections:** Only use self-locking snap hooks and Karabiners with any KStrong Fall Protection equipment. Do not use equipment that is not compatible.

MAINTENANCE, CLEANING & STORAGE:

Repairs to equipment can be made only by a KStrong representative or person or entity authorized by KStrong. Contact KStrong for maintenance and repair. Cleaning after use is important for maintaining the safety and life of the equipment. Cleanse the equipment of all dirt, corrosives, and contaminants. If the equipment cannot simply be wiped clean, use a mild soap and water. Rinse, wipe, and hang to dry in shade.

Store the anchorage connector component in a cool, dry and clean place out of direct sunlight. Avoid areas where heat, moisture, light, oil, and chemicals or their vapors or other degrading elements may be present. Equipment which is damaged or in need of maintenance should not be stored in the same area as usable equipment. Heavily soiled, wet, or otherwise contaminated equipment should be properly maintained (e.g. dried and cleaned) prior to storage.

Prior to using equipment which has been stored for long periods of time, a Formal Inspection should be performed by a competent person. For harnesses with Dielectric buckles, pass-thru buckles or Quick Connect Buckles, store the harness with the buckles connected.

TRAINING:

It is the responsibility of the users to ensure that they read, understand, and follow all instructions and are trained in the care and use of this device. Training should be repeated periodically and any time there is a change of components within the system. Training must be conducted without exposing the trainee to a fall hazard

- **As Per OSHA:** Anchorages used for attachment of personal fall arrest systems shall be independent of any anchorage being used to support or suspend platforms and capable of supporting at least 5,000 lbs. (23kN) per user attached, or be designed, installed and used as part of a complete PFAS which maintains a safety factor of at least two, and is under the supervision of a qualified person.

MARKING



NOTE

Do not attempt to disassemble the unit or make repairs to the equipment. Send the equipment back to the manufacturer, or persons or entities authorized in writing by the manufacturer to make repairs to the equipment.

LIFESPAN: The estimated product Lifespan is 10 years from the date of manufacturing. The following factors can reduce the Lifespan of the product: intense use, contact with chemical substances, especially aggressive environments, extreme temperature exposure, UV exposure, abrasions, cuts, violent impacts, bad use or maintenance.

DISCLAIMER: Prior to use, the end user, must read and understand the manufacturer's instructions supplied with this product at the time of shipment and seek training from their employer's trained personnel on the proper usage of the product. Manufacturer is not liable or responsible for any loss, damage or injury caused or incurred by any person on grounds of improper usage or installation of this product.

EQUIPMENT RECORD				
Product:				
Model and type/identification	Trade name	Identification number		
Manufacturer	Address	Tel, fax, email		
Year of manufacture	Purchase date	Date first put into use		
Other relevant information (e.g. Document number)				
PERIODIC EXAMINATION AND REPAIR HISTORY				
Date	Reason for entry (periodic examination or repair)	Defects noted, repair carried out and other relevant information	Name and signature of competent user	Periodic examination next due date

Certification Body & Ongoing Assessment Body (AUSTRALIA & NZ STANDARDS)
BSI Group ANZ Pty Ltd, Suite 1, Level 1, 54 Waterloo Road, Macquarie Park, NSW 2113, Australia.



KStrong Australia Pty Ltd
Unit 4-5 20 Lathe Place, Unanderra, New South Wales, Australia 2526
Contact Email: customercare@kstrong.com.au

www.kstrong.com

USA	South America	Asia	Australia	New Zealand
-----	---------------	------	-----------	-------------

KS GROUP

UKS/AF/AF890501/131025/V1