



USER INSTRUCTION MANUAL
ABSEILING ANCHOR

THESE INSTRUCTIONS APPLY TO THE FOLLOWING MODEL:

AFA930002

EN 795:2012 Type A
TS16415:2013 Type A

Please read and understand the manufacturer's instructions for each component or part of the complete system. Manufacturer's instructions must be followed for proper use, care, and maintenance of this product. These instructions must be retained and be kept available for the user's reference at all times. Alterations or misuse of this product, or failure to follow instructions, may result in serious injury or death.

Note: The user is advised to keep this user instructions document for the life of the product.

- 1. INTRODUCTION:** This Anchor is made in compliance with European Standard EN 795:2012 Type A / TS16415:2013 Type A for four user.

This Anchor is designed to minimise the risk of/provide protection against the danger of falling from heights. **However, always remember that no item of PPE can provide full protection and care must always be taken while carrying out the risk related activity.**

- 2. PERFORMANCE AND LIMITATIONS OF USE:** This Anchor has been tested in accordance with EN 795:2012 Type A / TS16415:2013 Type A and has achieved the following performance levels-

EN 795:2012 Type A test	Result/Comment
General Requirements for Anchor devices (Clause 4.1)	(PASS) No sharp edges (PASS).
Static Strength (Clause 4.4.2.3)	Sustained a force of 12 kN for 3 minutes (PASS).
Dynamic Strength & Integrity Test (Clause 4.4.1.2)	When tested with rigid steel mass of 100 kg, the test mass held after test with the device remaining stable throughout, (PASS). Anchor Holds an increased load of 300kg for 3 min following dynamic test.
Corrosion Resistance (Clause 4.2.2.1)	No corrosion evident after 48 hours of salt spray testing. (PASS)

TS16415:2013 Type A	Result/Comment
General Requirement (Clause 4.1)	Pass
Static Strength (Clause 4.2.1.2)	Sustained a static load of 15 kN (Depending by the Maximum Number of users declared as 4)
Dynamic Strength & Integrity (Clause 4.2.1.1)	When subjected to a 200kg mass with free fall calculated as per clause 5.1, anchor arrested the mass and held clear of the ground. Peak load recorded in test report. After each dynamic test, device held the rigid test mass clear off the ground with an increased load of 600kg for 3min. For each additional user 150kg load increased and mass held clear off ground for 3 min.

- 3. APPLICATION** - The AFA930002 Abseiling Anchor is used to create a safe connection point on walls, ceilings, rooftops, or steel structures. It allows workers to safely attach their fall protection equipment while working at height.
- 4. INSPECTION:** Visually inspect the system before each use to ensure that it is in a serviceable condition and is operating correctly. If during inspection, doubts are raised about the safety of the system or a component, these should be replaced either by the manufacturer or a competent person.
- 5. PRECAUTIONS:**
 - Ensure the Medical condition of the user does not affect his safety in normal and emergency use.
 - The equipment shall only be used by a person trained and competent in its safe use.
 - A rescue plan shall be in place to deal with any emergencies that could arise during the work.
 - Ensure that the anchor is installed directly above the user's head.
 - It is essential to verify free space required beneath the user at work place before each occasion of use so that in case of a fall there will be no collision with ground or other obstacle in the fall path.

6. PRE-USE CHECK:

- It is important to check before use, any dangers that may arise by the use of combinations of items of the equipment in which the safe function of any one item is affected by or interferes with the safe function of another.
- Carry out a pre-use check of the system, to ensure that it is in a serviceable condition and operates correctly before it is used.
- Ensure the compatibility of items of equipment when assembled into a system.

Visible Damage Or Deterioration

- Cracks, Deformations, or Rust: Check for any physical damage such as cracks, bends, or rust, especially in metal posts. These indicate that the post might be compromised and could fail under load.
- Corrosion: Rust or corrosion can weaken the structural integrity of the post, making it unsafe to use.
- Wear and Tear: Frequent use or harsh environmental conditions may cause the post to wear out over time.

6. INSTALLATION -

STEP 1: Make a drill of Ø18mm on the concrete section. Make sure the thickness of the concrete structure is 4 inches minimum and the distance between the edge & the hole should be 7.87 inches minimum. Clean the hole immediately before setting the anchor, remove drilling dust and standing water from the base of the hole by blowing out well with at least 4 strokes of the blow out pump, or using compressed air or an industrial vacuum cleaner, the anchor hole must be free of dust, water, ice, oil, bitumen, chemicals or any other foreign matter or contaminants.

STEP 2: Check that the hole is drilled to the correct depth before setting the anchor. Hole depth is correct when the chemical fastener contact the base of the hole and setting depth mark coincides with the concrete surface. Now push the chemical pouch into the drilled hole.

STEP 3: Use the setting tool to drive the chemical fastener into the hole applying moderate pressure, stop the setting tool when the setting depth is reached and leave it for minimum 24 Hours to get the chemical cured.

STEP 4: Insert the Flange Anchor followed by the washer and tighten the nut to the fullest.

STEP 5: Now the eye of the flange anchor can / may be used as anchorage point.

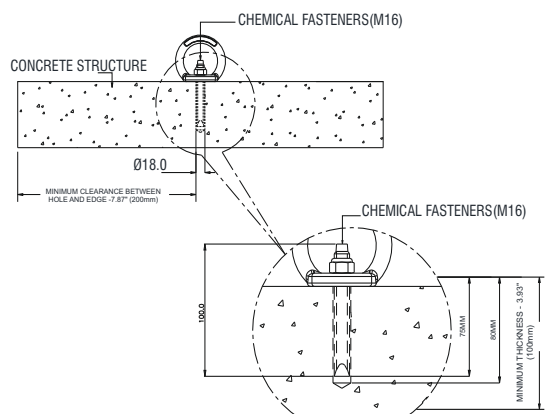
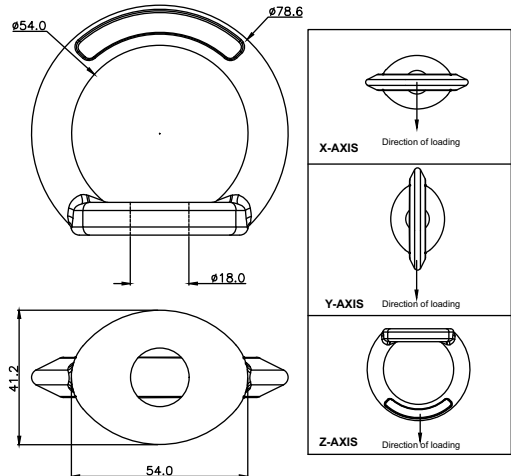

6. **RESCUE PLAN:** It is mandatory to ensure that users have a project-specific rescue plan and the means to execute it while using this equipment. Employees must be trained in self-rescue, or alternative means shall be provided for prompt rescue in the event of a fall. Always work in a pair to ensure that in an event of a fall your partner may help in rescue.
7. **LIMITATIONS:**
- The Anchor plates should be the personal property of its user.
 - They should not be used in highly acidic or basic environment.
 - Ensure that the equipment is compatible with other items when assembled into a system.
 - Ensure that the structure on to which the anchor is fitted is strong enough to withstand a load of 20 kN.
 - Anchor is compatible to be used with connectors i.e. Karabiners, Hooks (EN 362:2004).
 - It is essential for the safety of the user that if the product is resold outside the original country of destination, the reseller must provide instructions for use, maintenance, periodic examination and repair in the language of the country in which the product is to be used.
 - A full body harness is the only acceptable body holding device that can be used in a fall arrest system.
 - Always use the dorsal attachment of the harness to connect to the system with the help of steel (swivel) snap hook.
 - When Anchor device is used as part of a fall arrest system, the user shall be equipped with a means of limiting the maximum dynamic forces exerted on the user during the arrest of a fall to a maximum of 6 kN.
 - Anchor Device must be marked with Last Inspection date.
 - Following conditions may be hazardous and may affect the performance of Anchor.
 - Extreme temperature.
 - Trailing or looping of Lanyards over sharp edges.
 - Extreme acidic or basic environments.
 - Abrasive or sharp edge structures which can damage the equipment.
 - Chemical Reagents.
 - Climatic exposure.
 - When the equipment become wet, either from being in use or when due to cleaning. It should be allowed to dry by itself and be kept away from open fire or any other source of heat.
 - User must check for the legibility of product marking before each and every use.
 - For safety reasons and before each use, make sure that in the event of a fall there is no obstacle obstructing the normal deployment of the fall arrest system fixed on this anchor point.
 - It is essential for safety that equipment is withdrawn from use immediately should: any doubt arise about its condition for safe use or; it have been used to arrest a fall and not used again until confirmed in writing by a competent person that it is acceptable to do.
 - The maximum load that could be transmitted in service from the anchor device to the structure is 15kN.
 - After installation, copies of the installation documentation should be handed over to the user. This documentation should be kept in the building for the purpose of subsequent examinations of the anchor device.
 - The schematic plan should be affixed to the building so as to be visible or available for everybody (e.g. at the roof access point).
8. **COMPATIBILITY:** To optimise protection, in some instance it may be necessary to use an anchor with suitable boots/gloves/helmet/ear defenders. In this case, before carrying out the risk-related activity, consult your supplier to ensure that all protective equipment are compatible and suitable for your intended application.
9. **STORAGE AND TRANSPORT:** When not in use, store the anchor in a well-ventilated area away from coarse acidic or basic environment. Never place heavy items on top of an anchor, ensure that it is stored away from chemically hazardous environment. Preferably storage should be in dry environment.
10. **REPAIR:** If the product becomes damaged, it will NOT provide the optimum level of protection, and therefore it must be immediately replaced. Never use damaged product.
11. **WITHDRAWAL FROM USE:** If the system has been used to arrest a fall, it must be removed from service and returned to the manufacturer or a competent repair centre for servicing and re test.
12. **CLEANING:** In case of minor soiling, wipe the anchor with cotton cloth or a soft brush. Do not use any abrasive material. For intensive cleaning, wash the anchor in water at a temperature between 30°C to 60°C by using a neutral detergent (pH 7). The washing temperature should not exceed 60°C. Do not use acidic or basic detergents.

13. WARNING:

- Do not make any alterations or additions to the equipment without the manufacturer's prior written consent and that any repair shall only be carried out by personnel trained by the manufacturer and duly authorized by him.
- The equipment shall not be used outside its limitation, or for any purpose other than that for which it is intended.
- It is essential for safety of the user that equipment is immediately withdrawn from use should it has been used to arrest a fall. Do not use the product until confirmed in writing by a competent person that it is acceptable to do so.
- It is important to conduct regular periodic examination of the product because the safety of the user depends upon the continued efficiency and durability of the product.
- It is recommended to conduct regular periodic examination of the equipment, depending on the usage frequency, environmental conditions, and applicable legislation.
- It is important to conduct a periodic examination by a competent person at least once in 12 months.
- Please ensure to follow the installation steps recommended here to achieve the stability of the anchor device during usage. This is important for the safe and intended use of the product.
- The anchor device should only be used for personal fall protection equipment, not for lifting equipment.
- The anchor device should be installed only by competent persons or competent organizations.
- The installation should be verified appropriately, e.g. by calculation or testing.
- Marking or the anchor device is accessible after installation, additional marking near the anchor device is not required.
- Declarations given by the installer in charge should be undersigned by him/her and should contain at least information that the anchor device:
 - was installed in accordance with the manufacturer's installation instructions;
 - was carried out according to the plan;
 - was fixed to the specified substrate;
 - was fixed as specified (e.g. number of bolts, correct materials, correct position/location);
 - was commissioned in accordance with the manufacturer's information;
 - was supplied with photographic information/ documentation, especially where fixings (e.g. bolts) and the Underlying substrate are no longer visible after completing the installation.

- MARKING -

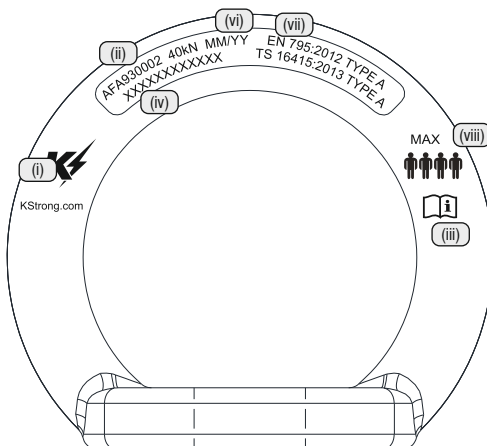

The Anchor is marked with -

- (I) Identification of the manufacturer
- (ii) Ref. No.
- (iii) Read The Instruction Before Use.
- (iv) UID No. for traceability
- (v) Is appropriate for minimum 4 users..
- (vi) Manufacturing date
- (vii) Norm Reference.

PERIODIC EXAMINATION PROCEDURE

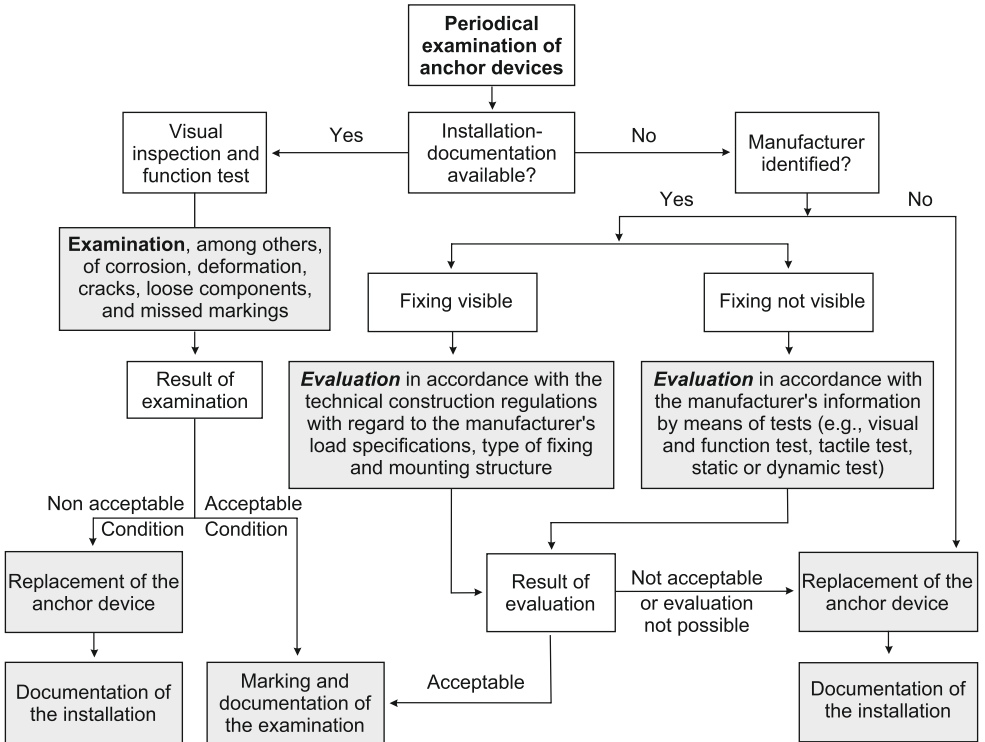

Certification Body :
ANCCP CERTIFICATION ANGENC S.R.L, Via Dello Struggino 6 57121, LIVORNO (ITALY)

For EU Declaration, please visit <https://kstrong.com/asia/eu-declaration-form/>



KStrong Australia Pty Ltd
Unit 4-5 20 Lathe Place, Unanderra, New South Wales, Australia 2526
Contact Email: customercare@kstrong.com.au

www.kstrong.com

USA	South America	Asia	Australia	New Zealand
-----	---------------	------	-----------	-------------

KS GROUP