

EXTREME TYPE B WINCH 20M

AFT730042

KStrong Extreme Winches have been designed for lifting and lowering, ideal for a range of applications including confined space work, rescue, positioning and personnel / material handling. The Type B Winch is equipped with a unique Secondary Brake mechanism providing additional safety to the user.

Features

- Material or Man-lifting rescue 20m winch.
- Comes with universal mounting bracket to attach the Extreme Davits and Tripods for quick and easy installation.
- Handle rotating mechanism for lifting or lowering.
- Equipped with Advanced Dual Load Advantage (DLA) Gear System to give an effortless use of the Winch.
- Personal - As per EN 1496 Rated 140kg
- Materials - As per Machine Directive 2006/42/EC Rated 250kg
- For Personal use, it is recommended to use in-conjunction with a Fall Arrest Block as back up.

How To Use

Refer to User Instruction Manual 

Metal Components

Material	: Galvanized Steel Body
Finish	: Nylon Molded Cover & Beam for wire winding
Minimum Strength Breaking	: 15kN
Wire Cable	: 4.8mm Galvanized Steel
ANSI Steel Snap Hook	: 23kN MBS, Gate Strength 16kN

Weight

11.49kg ± 0.010kg

System Strength

15kN

Relevant Standards

Tested as per EN 1496:2017 Class B & AS/NZS 1891.3 2020
ATEX Certified

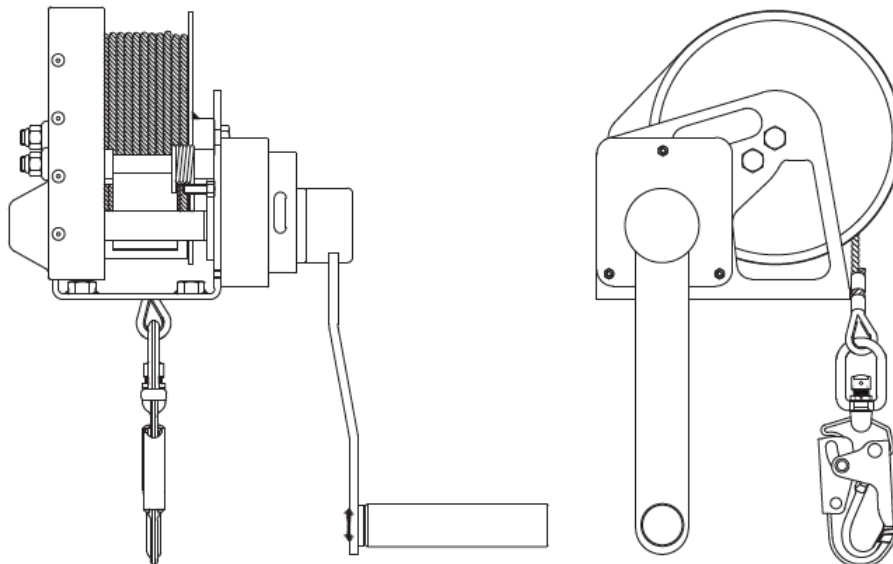

II 2G
Ex h IIc T6 Gb
EN 80079-36:2016
EN 80079-37:2016