

# FLANGE ADAPTER PLATE WITH SWIVEL EYE

AFT730013

## Features

- Anchor point for Pole Hoist System to be used to access side entry vessels and tanks.
- Can be used for Vertical and Horizontal entry
- When used with the AFT751080 Pole Hoist it provides retrieval and fall protection when limited overhead clearance is available.
- Simple to install by using the existing Studs on the flange.

## How To Use

Refer to User Instruction Manual



## Metal Components

Material	:	Aluminum Alloy ED Coated Grey
Finish	:	ED Coated Grey
Minimum Breaking Strength	:	23 kN
Swivel	:	Aluminum Alloy

## Weight

6.204 kg ± 0.10 kg

## Rating

23 kN

## Relevant Standards

Tested as per EN 795:2012 Type A

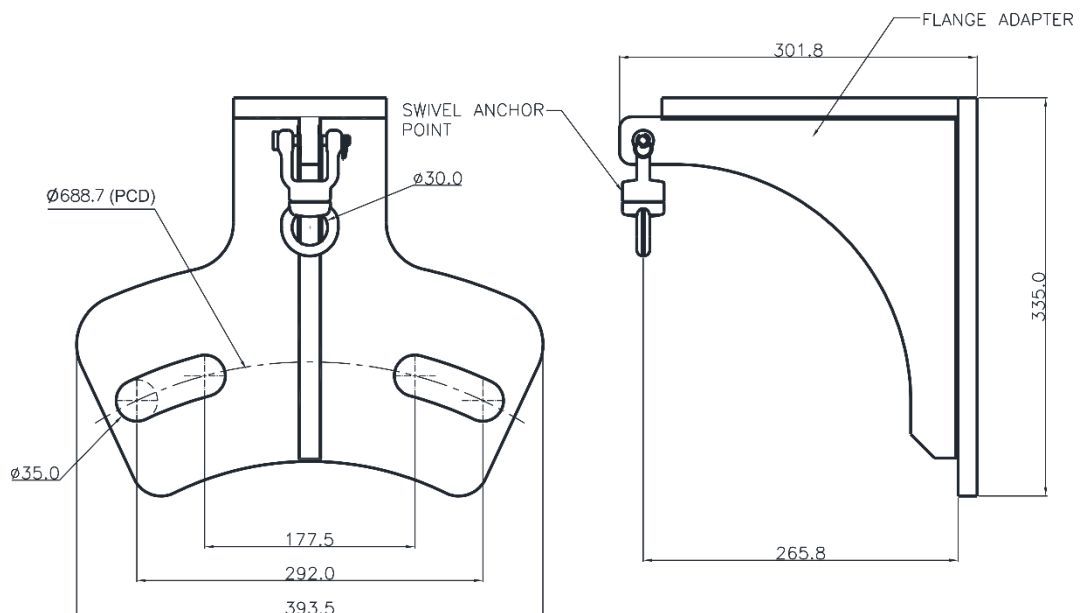

CE 0598