

USER INSTRUCTION MANUAL  
EDGE BEAM ANCHORS

THESE INSTRUCTIONS APPLY TO THE FOLLOWING MODELS:

AFA930401, AFA930411, AFA930412 and AFA930413

**CE 0598**  
EN 795:2012 Type B



II 2G

Ex h IIc T6 Gb

EN 80079-36:2016

EN 80079-37:2016

CERTIFIED PRODUCT



AUSTRALIA & NZ STANDARDS  
Certified to AS/NZS 5532:2013  
Issued by BSI  
Vide Lic. No.: BMP 760374

Please read and understand the manufacturer's instructions for each component or part of the complete system. Manufacturer's instructions must be followed for proper use, care, and maintenance of this product. These instructions must be retained and be kept available for the user's reference at all times. Alterations or misuse of this product, or failure to follow instructions, may result in serious injury or death.

**Note:** The user is advised to keep this user instructions document for the life of the product.

1. **INTRODUCTION:** The Edge Beam Anchors are classed as a Personal Protective Equipment (PPE) by the European PPE Regulation (EU)2016/425 and have been shown to comply with this Regulation through the Harmonized European Standard EN 795:2012 Type B.

These Anchors are designed to minimise the risk of/provide protection against the danger of falling from heights. However, always remember that no item of PPE can provide full protection and care must always be taken while carrying out the risk related activities.

2. **PERFORMANCE AND LIMITATIONS OF USE:**

The Anchors have been tested in accordance with EN 795:2012 Type B and have achieved the following performance levels-

EN 795 : 2012 Type B	Result/Comment
General (Clause 4.1)	(PASS)
Static Strength (Clause 4.4.2.3)	Sustained a force of 12 kN for 3 Min. (PASS)
Dynamic Strength (Clause 4.4.2.2)	When tested with rigid steel mass of 100 kg, the test mass held after test with the remaining stable throughout. (PASS)
Corrosion Resistance (Clause 4.2.2.2)	No corrosion evident after 48 hours of salt spray testing (PASS)

3. **APPLICATION:**

The beam anchor is a temporary and transportable anchor point (EN795:2012 Type B), it is intended to be used where a metal beam constitutes an adequate anchor structure. It must be installed on a beam strong enough to withstand a load applied in the direction of use, at least 12 kN for a user.

#### 4. PRE- USE INSPECTION:

- Visually inspect the system before each use to ensure that it is in a serviceable condition and is operating correctly. If during inspection, doubts are raised about the safety of the system or a component, these should be replaced either by the manufacturer or a competent person.
- It is recommended that the user **MUST** carry out a pre-use inspection of the equipment, to ensure that it is in a serviceable condition and operates correctly before it is used.
- A rescue plan shall be in place to deal with any emergencies that could arise during the work.
- While using, make sure that the mobile plates and locking screws remain duly in position and locked. It is recommended to ensure that the steel beams are equipped with end stops to prevent the anchor to leave the beam unintentionally.
- Ensure that the beam anchor is installed directly above the user's head. It is recommended that the installation of this anchor point be supervised by a qualified person.
- In any case, connections between the attachment D-Ring and the fall arrest system will have to be made through a connector (EN362) During the use, please check regularly that the connector is correctly closed.
- Make sure that the work is done in such a way as to limit the pendulum effect, as well as the risk and the height of a fall.
- For safety reasons and before each use, make sure that in the event of a fall there is no obstacle obstructing the normal deployment of the fall arrest system fixed on this anchor point.
- Before each occasion of use, it is essential to verify a free space required beneath the user at work place so that in case of a fall there will be no collision with ground or other obstacle in the fall path.

#### 5. PRECAUTIONS:

- Ensure the Medical condition of the user does not affect his safety in normal and emergency use.
- Ensure that the Anchor is installed directly above the user's head.
- Ensure that the equipment is compatible with other items when assembled into a system.

#### 6. INSTRUCTIONS FOR USAGE :

##### Beam anchor AFA930401 and AFA930411

Beam anchor AFA930401 is intended to be installed on flanges of beam from 90 mm to 340 mm width while AFA930411 is intended to be installed on flanges of beam from 75 mm to 150 mm width.

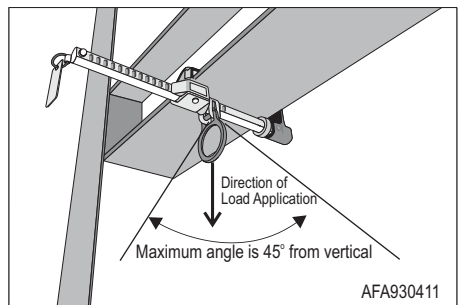
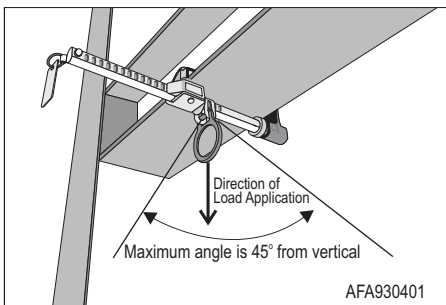

**How to Install-**

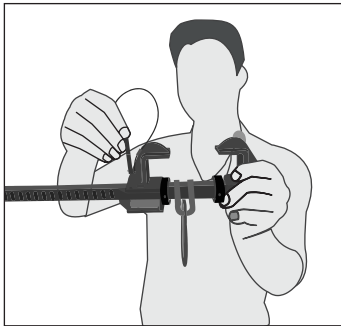

Unlock the detent pin to position the anchor on a beam.

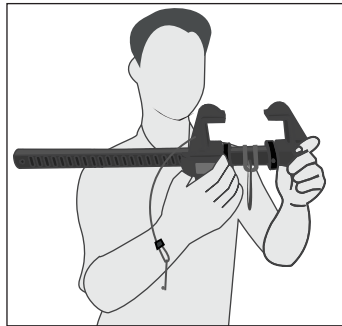

Push the latch and adjust the width of the movable jaw.

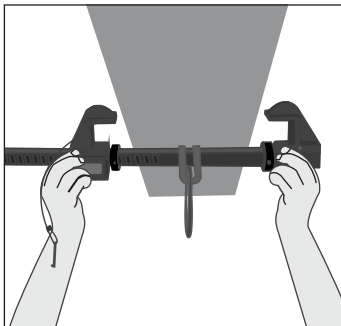

Allow the clamping jaws to fit over the flange of the beam and release the latch to lock its position.

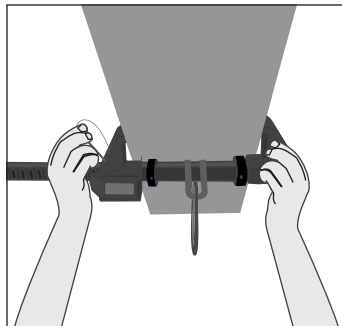

Use detent pin (attached with lock cable) to secure the position of latch from coming out accidentally.

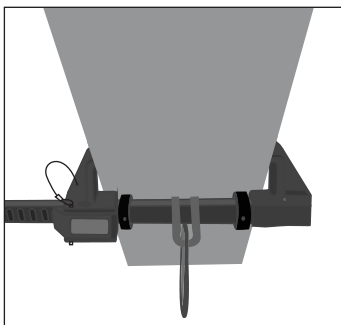

Use the D-ring as connecting point.

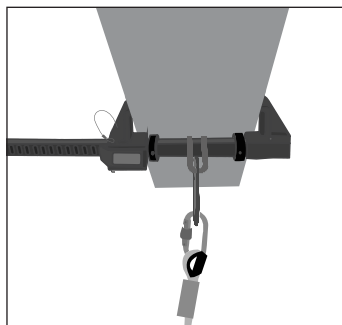

Connect a karabiner to the D-Ring & the Beam Anchor is ready to be used as an anchor point.

**Use of Beam Anchor Trolley AFA930412**

Beam Anchor Trolley is intended to be installed on flanges of beam from 80 mm to 250 mm width.

The Beam Anchor Trolley is a temporary and transportable anchor point (EN795: 2012 Type B), it is intended to be used where a metal beam constitutes an adequate anchor structure. It must be installed on a beam strong enough to withstand a load applied in the direction of use, at least 12 kN for a user. It is provided with 4 wheels and thus follows the user during its displacement along the metal beam without additional action required by the user.

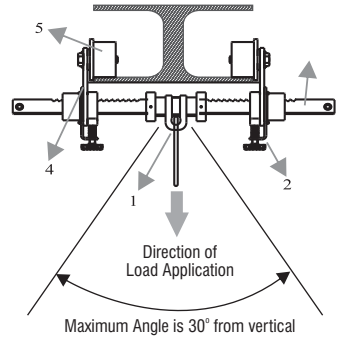

1	Anchor D-Ring
2	Snaps buttons / Locking Screw (x2)
3	Support bar with adjusting system
4	Mobile plates (x2)
5	Wheels (x4)

**Installation**

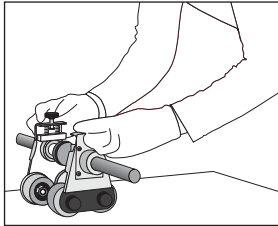

Unscrew the 2 locking screws.

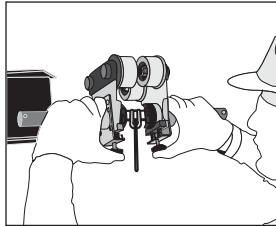

Press the 2 snap buttons.

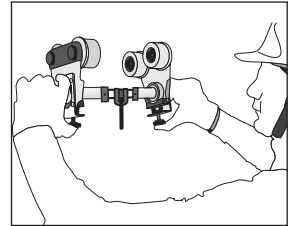

Open the mobile plates at the maximum.

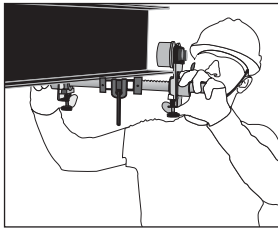

Put the beam anchor under the beam soleplate adjust the distance of the mobile plates so that the 4 wheels be as much in contact as possible with the beam soleplate.

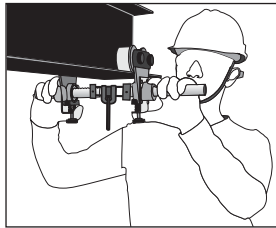

Once in position, release the snaps buttons and lock the adjustment by tightening the locking screw.

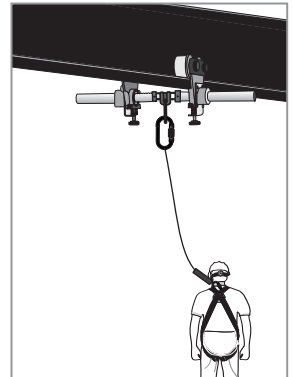

The shoulder of the wheels must not be supported on the beam soleplate.

During this operation, ensure that the D-Ring remains placed in the middle of the two mobile plates.

While using, make sure that the mobile plates and locking screws remain duly in position and locked.

It is recommended to ensure that the steel beams are equipped with end stops to prevent the anchor to leave the beam unintentionally.

6. Specifications of Vertical Beam Anchor (AFA930413):-

Material	System Strength
Aluminum Alloy & Steel.	Greater than 23 kN. (5000 lbs)

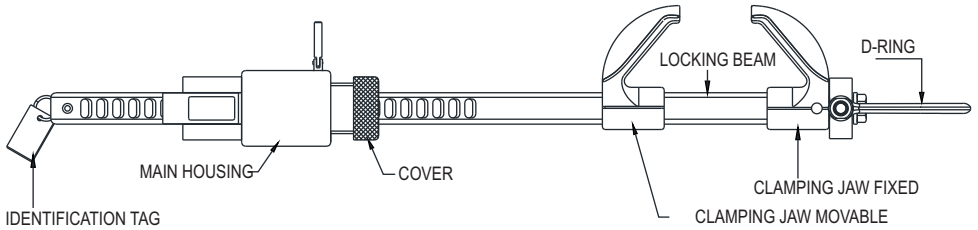

**Installation:** Beam anchor is intended to be installed on beam from 90.0 mm(3.54") to 340.0 mm(13.38") width.

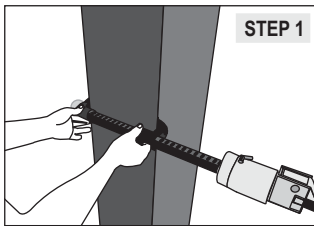

Place the fixed clamping jaw on one side of the beam and move-in the movable clamping jaw on the other.

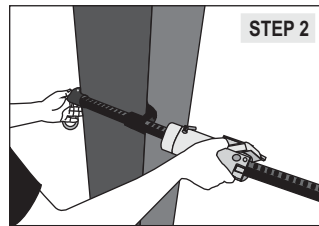

Hold the main housing as indicated in the figure and press the Anchor cast latch to move the main housing closer to the movable clamping jaw.

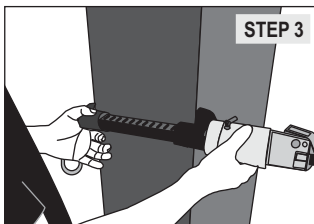

Adjust the main housing until the anchor cast latch clutches the nearest groove on the rod.

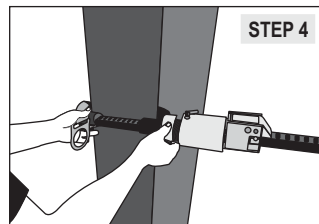

Now tighten the main housing cover over the movable clamping jaw.

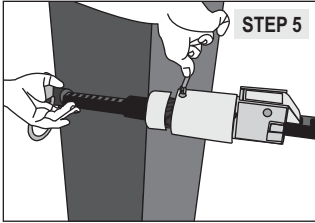

After tightening the main housing, lock it using the threaded locking pin provided on the main housing by turning it in clock-wise direction till the required locking is achieved.

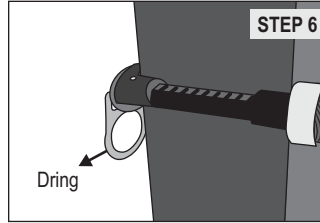

Now Swivel D-ring can be used as an anchor point.

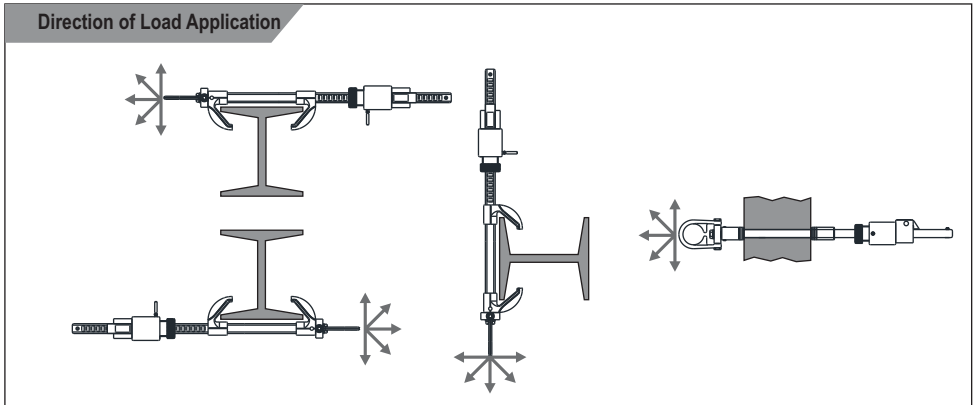

7. **ANCHORAGE STRUCTURE STRENGTH:** Ensure that the structure on to which the anchor is fitted is strong enough to withstand a minimum load of 12 kN.
8. **COMPATIBILITY:** To optimize protection, in some instance it may be necessary to use the anchor with suitable PPE such as: boots/gloves/helmet and ear protection. In this case, before carrying out the risk-related activity, consult your supplier to ensure that all your protective products are compatible and suitable for your application.
9. **LIMITATIONS:**
  - It should be the personal property of it's user.
  - It should not be used in highly acid or basic environment.
  - The anchor has been tested to EN 795:2012 Type B and is appropriate only for single person use with an energy absorber as per EN 355:2002.
  - The equipment shall only be used by a person trained and competent in its safe use.
  - It is essential for the safety of user that if the product is resold outside the original country of destination, the reseller shall provided instruction for use, for maintenance, for periodic examination and for repair in the language of the country in which product is to be used.
  - A full body harness is the only acceptable body holding device that can be used in a fall arrest system.
  - Always use the dorsal attachment of the harness to connect to the system with the help of steel (swivel) snap hook.

- When Anchor device is used as part of a fall arrest system, the user shall be equipped with a means of limiting the maximum dynamic forces exerted on the user during the arrest of a fall to a maximum of 6 kN.
  - Anchor Device must be marked with Last Inspection date.
  - Following conditions may be hazardous and may affect the performance of Anchor.
    - Extreme temperature.
    - Trailing or looping of Lanyards over sharp edges.
    - Extreme acidic or basic environments.
    - Abrasive or sharp edge structures which can damage the equipment.
    - Chemical Reagents.
    - Climatic exposure.
  - The user must carry out a pre-use check of the Anchor to ensure that it is in a serviceable condition and operates correctly before it is used.
  - When the equipment become wet, either from being in use or when due to cleaning. It should be allowed to dry by itself and be kept away from open fire or any other source of heat.
  - The Safety of users depends upon the continued efficiency and durability of the equipment.
  - Periodic Examination are only to be conducted by a competent person for periodic examination.
  - User must check for the legibility of product marking before each and every use.
  - There is no permanent deflection or displacement on the device.
  - Be aware of any dangers that may arise by the use of combinations of items of equipment in which the safe function of any one item is affected by or interferes with the safe function of another.
  - Anchor slide should move freely, Please check for any cracks, permanent deformation.
- 10. REPAIR:** If the product becomes damaged, it will NOT provide the optimum level of protection, and therefore should be immediately removed from service. It needs to be inspected to see if it is replaced or repaired. Never use the damaged product. Repair is only permitted by the manufacturer or a nominated repair centre or individual approved by the manufacturer.
- 11. WITHDRAWAL FROM USE:** If the system has been used to arrest a fall, it should be removed from service and returned to the manufacturer or a competent repair center or servicing and re-test.
- 12. CLEANING AND MAINTENANCE:** In case of minor soiling, wipe the anchor with cotton cloth or a soft brush. Do not use any abrasive material. For intensive cleaning wash the anchor in water at a temperature between 30°C to 60°C by using a neutral detergent (pH 7). The washing temperature should not exceed 60°C. Do not use acidic or basic detergents.
- 13. STORAGE AND TRANSPORT:** When not in use, store the anchorage device in a well-ventilated area away from heavily acidic or basic environment. Never place heavy items on top of it. Also ensure that it is stored away from chemically hazardous environment preferably storage should be in dry environment. Ensure that manufacturer's packing is used during transportation to prevent damage. In case original packing is not available, use polybag which is sealed to prevent moisture.
- 14. WARNING:**
- Do not make any alterations or additions to the equipment without the manufacturer's prior written consent and that any repair shall only be carried out by personnel trained by the manufacturer and duly authorized by him.
  - The equipment shall not be used outside its limitation, or for any purpose other than that for which it is intended.
  - It is essential for safety of the user that equipment is immediately withdrawn from use once it has been used to arrest a fall. Do not use the product until confirmed in writing by a competent person that it is acceptable to do so.
  - Only the models with the Ⓢ marking on the product itself are suitable for use in an Explosive Atmosphere.
- Note :-** That the anchor device should only be used for personal fall protection equipment and not for lifting equipment.
- 15. PERIODIC EXAMINATION:**
- It is important to conduct regular periodic examination of the product because the safety of the user depends upon the continued efficiency & durability of the product.
  - The frequency of examination should be at least once in a year however it can be more than once if legislation requires, or frequency of use is high or environmental conditions have an adverse effect on it eg. excessive rain, sea side environment, excessive heat etc.
  - It is emphasized that the examination be conducted Only by the manufacturer or by a person / organization authorized by the manufacturer strictly in accordance with their periodic examination procedures.
  - It is also advised the competent person be duly trained and authorized by the manufacturer.
  - Ensure that all markings on the product are legible and can be clearly read.



**MARKING:**



**KSTRONG®**  
UNRIVALED SAFETY.  Read the user instructions carefully before each use.

**Vertical Beam Anchor**  
**AFA930413**

Minimum Breaking Strength: 23kN (5000lbs)  
Service Temperature: -30°F to 130°F (-34°C to 54°C)  
Complies with EN 795:2012 Type B, AS/NZS 5532:2013 & ANSI Z359.18-2017 Type A

DOM:

**KStrong Asia Pte Ltd, 33A Chander Road, Singapore 219539**

**MAX** 

**WARNING:**

Read carefully the manufacturer's instructions provided with this product at the time of shipment for proper use, maintenance and inspection. Use only with EN365 of PPE regulation 2016 and ANSI/OSHA compliant personal fall arrest or restraint system. Ensure beam anchor is adjusted tightly on beam flange. Make only compatible connection.

Any alteration, misuse or failure to follow instructions may result in serious injury or death.

**ANY ALTERATION, ABUSE OR MISUSE OF THIS PRODUCT VOIDS THE WARRANTY.**

**DO NOT REMOVE THIS LABEL.**

**SPECIFICATIONS:** Maximum Capacity is one person with a maximum weight of 140kg (310lbs) , when used as a single point anchor connector for a personal fall arrest or restraint system. Flange Width: 3.54" - 13.4" (90mm - 340mm)

**MATERIALS OF CONSTRUCTION:** Locking beam - High Strength Aluminum Alloy, Main Housing with Cover - High Strength Aluminum Alloy, D-Ring - Alloy Steel, Flange is made of Alloy Steel.

**Direction of Load Application**

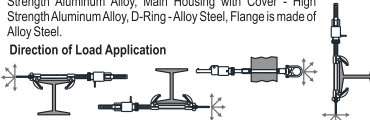

**Inspection Grid** Made In India

Yr	M	J	F	M	A	M	J	J	A	S	O	N	D
20													
20													
20													
20													
20													
20													
20													
20													
20													
20													

**Inspection-** Before every use, user must inspect the product. Every 6 months a competent person must complete final inspection of the product and record initials.

**THE ANCHOR IS MARKED WITH:**

- i) The CE mark showing that the product meets the requirements of the PPE Regulation (EU) 2016/425
- ii) Identification of the manufacturer
- iii) Type or product code
- iv) Product description
- v) UID No. for traceability
- vi) Norm Reference
- viii) Read the instruction Before Use.
- ix) Atex marking

**MARKING:-****THE ANCHOR IS MARKED WITH:**

- i) The CE mark showing that the product meets the requirements of the PPE Regulation (EU) 2016/425
- ii) Identification of the manufacturer
- iii) Product description
- iv) Type or product code
- v) UID No. for traceability
- vi) Norm Reference
- vii) Read the instruction Before Use.

**LIFESPAN:** The estimated product Lifespan is 10 years from the date of manufacture. The following factors can reduce the Lifespan of the product: intense use, contact with chemical substances, specially aggressive environments, extreme temperature exposure, UV exposure, abrasions, cuts, violent impacts, bad use or maintenance.

**DISCLAIMER:** Prior to use, the end user must read and understand the manufacturer's instructions supplied with this product at the time of shipment and seek training from their employer's trained personnel on the proper usage of the product. Manufacturer is not liable or responsible for any loss, damage or injury caused or incurred by any person on grounds of improper usage or installation of this product.

EQUIPMENT RECORD				
Product				
Model & type/Identification		Trade Name		Identification number
Manufacturer		Address		Tel, email into use
Year of manufacture		Purchase Date		Date first put into use
Other relevant information (eg. document number)				
PERIODIC EXAMINATION AND REPAIR HISTORY				
Date	Reason for entry (periodic examination or repair)	Defects noted, repairs carried out and other relevant information	Name and signature of competent person	Periodic examination next due date

**Certification Body:**

SATRA Technology Europe Ltd, Bracetown Business Park, Clonee, Dublin D15 YN2P Ireland (Notified Body 2777)

**Ongoing Assessment Body:**

SGS Fimko Oy, Takomotie 8, FI-00380 Helsinki, Finland (Notified Body 0598)

For EU Declaration, please visit <https://kstrong.com/asia/eu-declaration-form/>



**KStrong Asia Pte Ltd**

33A Chander Road, Singapore 219539  
Contact Email: [customer care@kstrong.com](mailto:customer care@kstrong.com)

[www.kstrong.com](http://www.kstrong.com)

---

USA

South America

ASIA

---